

Operation & Maintenance Manual

SEAM036200P

D61EX-12 D61PX-12 BULLDOZER

SERIAL NUMBERS D61EX-1001 and up
D61PX-1001

WARNING

Unsafe use of this machine may cause serious injury or death. Operators and maintenance personnel must read this manual before operating or maintaining this machine. This manual should be kept near the machine for reference and periodically reviewed by all personnel who will come into contact with it.

NOTICE

Komatsu has Operation & Maintenance Manuals written in some other languages. If a foreign language manual is necessary, contact your local distributor for availability.

KOMATSU

FOREWORD

FOREWORD

This manual provides rules and guidelines which will help you use this machine safely and effectively. The precautions in this manual must be followed at all times when performing operation and maintenance. Most accidents are caused by the failure to follow fundamental safety rules for the operation and maintenance of machines. Accidents can be prevented by knowing beforehand conditions that may cause hazard when performing operation and maintenance.

WARNING

Operators and maintenance personnel must always do as follows before beginning operation or maintenance.

- **Always be sure to read and understand this manual thoroughly before performing operation and maintenance.**
- **Read the safety messages given in this manual and the safety labels affixed to the machine thoroughly and be sure that you understand them fully.**

Keep this manual at the storage location for the Operation and Maintenance Manual given below, and have all personnel read it periodically.

If this manual has been lost or has become dirty and cannot be read, request a replacement manual immediately from Komatsu or your Komatsu distributor.

If you sell the machine, be sure to give this manual to the new owners together with the machine.

Komatsu delivers machines that comply with all applicable regulations and standards of the country to which it has been shipped. If this machine has been purchased in another country or purchased from someone in another country, it may lack certain safety devices and specifications that are necessary for use in your country. If there is any question about whether your product complies with the applicable standards and regulations of your country, consult Komatsu or your Komatsu distributor before operating the machine.

CALIFORNIA

Proposition 65 Warning

Diesel engine exhaust and some of its constituents are known to the State of California to cause cancer, birth defects, and other reproductive harm.

FOREWORD

FOREWORD

Storage location for the Operation and Maintenance Manual:

Machine equipped with cab

Inside of right and left doors

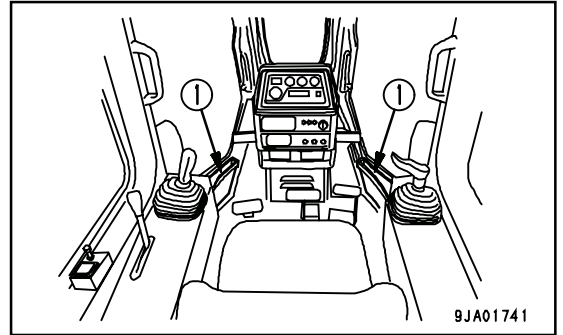

Machine without cab

Back pocket of operator's seat

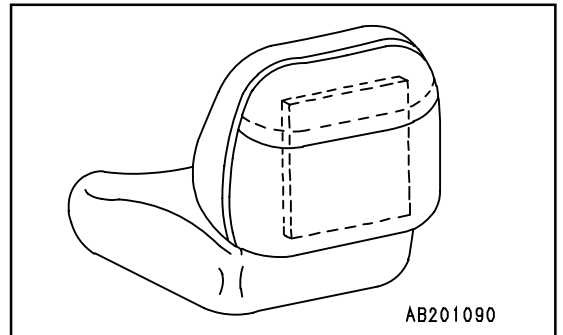

SAFETY INFORMATION

To enable you to use this machine safely, safety precautions and labels are given in this manual and affixed to the machine to give explanations of situations involving potential hazards and of the methods of avoiding such situations.

Signal words

The following signal words are used to inform you that there is a potential hazardous situation that may lead to personal injury or damage.

In this manual and on machine labels, the following signal words are used to express the potential level of hazard.

DANGER

Indicates an imminently hazardous situation which, if not avoided, will result in death or serious injury. This signal word is to be limited to most extreme situations.

WARNING

Indicates a potentially hazardous situation which, if not avoided, could result in death or serious injury.

CAUTION

Indicates a potentially hazardous situation which, if not avoided, may result in minor or moderate injury. It may also be used to alert against unsafe practices.

Example of safety message using signal word

WARNING

To avoid hitting unlocked operation levers, lower equipment to ground and move SAFETY LOCK LEVER (located near seat) to LOCK position before starting up from operator's seat. Sudden and unwanted machine movement can cause serious injury or death.

Other signal words

In addition to the above, the following signal words are used to indicate precautions that should be followed to protect the machine or to give information that is useful to know.

NOTICE

This word is used for precautions that must be taken to avoid actions which could shorten the life of the machine.

REMARKS

This gives information that is useful to know.

Safety labels

Safety labels are affixed to the machine to inform the operator or maintenance worker on the spot when carrying out operation or maintenance of the machine that may involve hazard.

This machine uses "Safety labels using words" and "Safety labels using pictograms" to indicate safety procedures.

Example of safety label using words

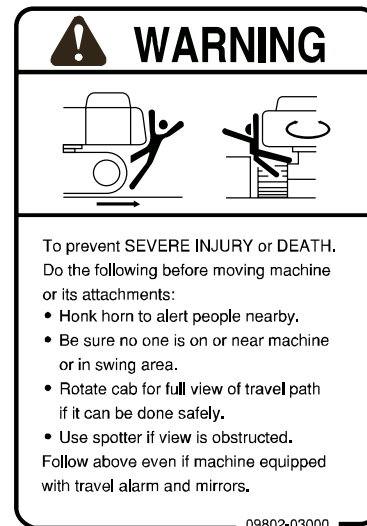

Part No.

Safety labels using pictogram

Safety pictograms use a picture to express a level of hazardous condition equivalent to the signal word. These safety pictograms use pictures in order to let the operator or maintenance worker understand the level and type of hazardous condition at all times. Safety pictograms show the type of hazardous condition at the top or left side, and the method of avoiding the hazardous condition at the bottom or right side. In addition, the type of hazardous condition is displayed inside a triangle and the method of avoiding the hazardous condition is shown inside a circle.



Part No.

Komatsu cannot predict every circumstance that might involve a potential hazard in operation and maintenance. Therefore, the safety messages in this manual and on the machine may not include all possible safety precautions. If any procedures or actions not specifically recommended or allowed in this manual are used, it is your responsibility to take the necessary steps to ensure safety.

In no event should you engage in prohibited uses or actions described in this manual.

The explanations, values, and illustrations in this manual were prepared based on the latest information available at that time. Continuing improvements in the design of this machine can lead to changes in detail which may not be reflected in this manual. Consult Komatsu or your Komatsu distributor for the latest available information of your machine or for questions regarding information in this manual.

The numbers in circles in the illustrations correspond to the numbers in () in the text. (For example: ① → (1))

INTRODUCTION

This Komatsu machine is designed to be used mainly for the following works:

- Dozing
- Smoothing
- Cutting into hard or frozen ground or ditching.
- Felling trees, removing stumps

See the section "WORK POSSIBLE USING BULLDOZER (PAGE 3-77)" for further details.

FRONT/REAR, LEFT/RIGHT DIRECTIONS OF MACHINE

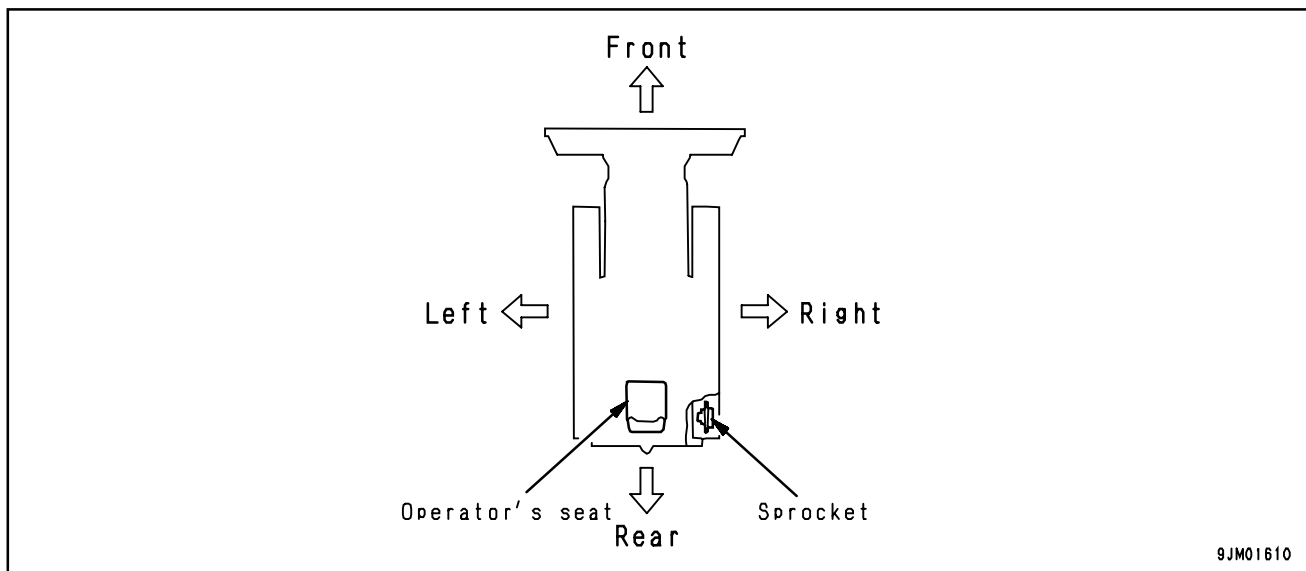

In this manual, the terms front, rear, left, and right refer to the travel direction as seen from the operator's cab when the operator's cab is facing the front and the sprocket is at the rear of the machine.

NECESSARY INFORMATION

When requesting service or ordering replacement parts, please inform your Komatsu distributor of the following items.

MACHINE SERIAL NO. PLATE AND POSITION

This is at the front bottom right of the operator's seat.

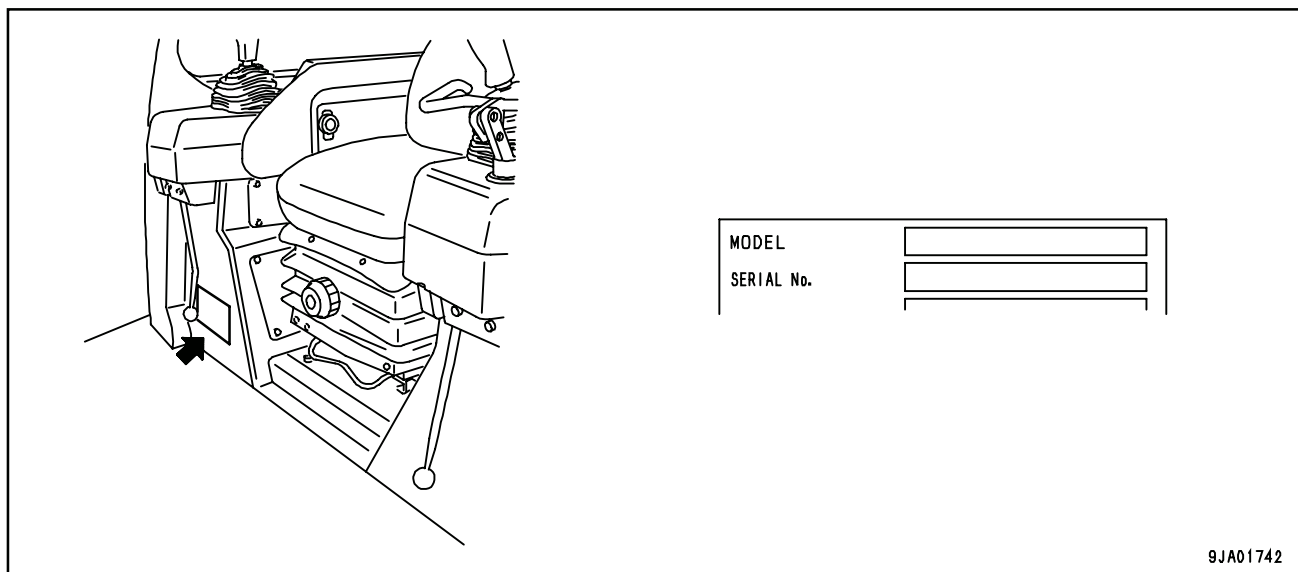

ENGINE SERIAL NO. PLATE AND POSITION

This is at the front top of the engine on the left side machine.

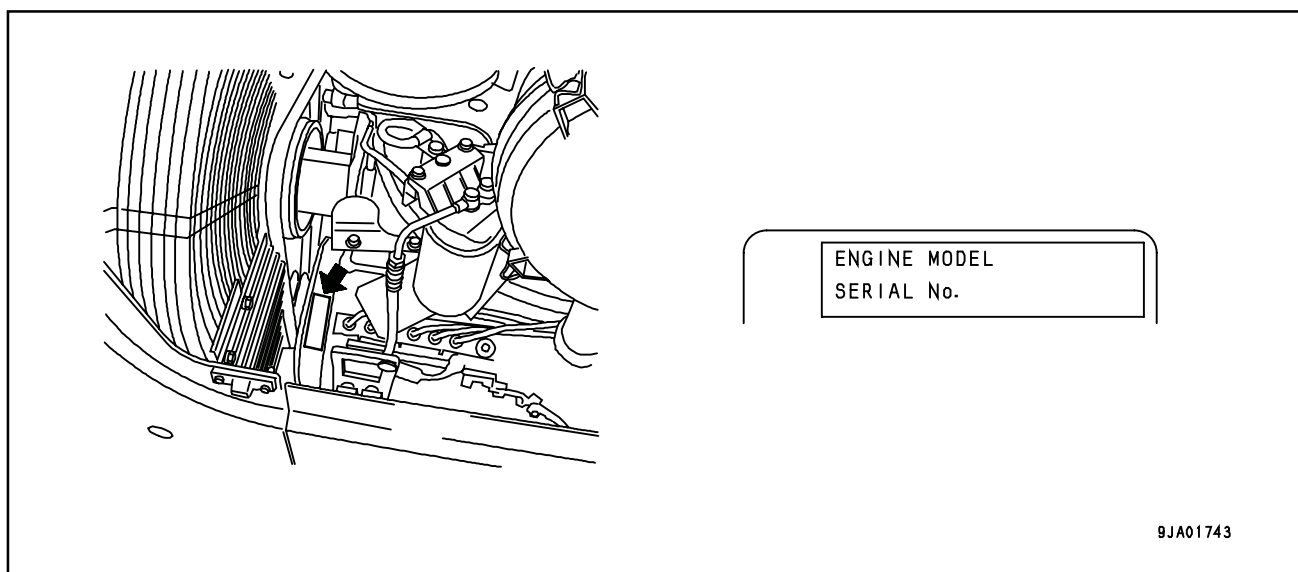

BLADE SERIAL NO. PLATE AND POSITION

This is at the rear right of the blade.

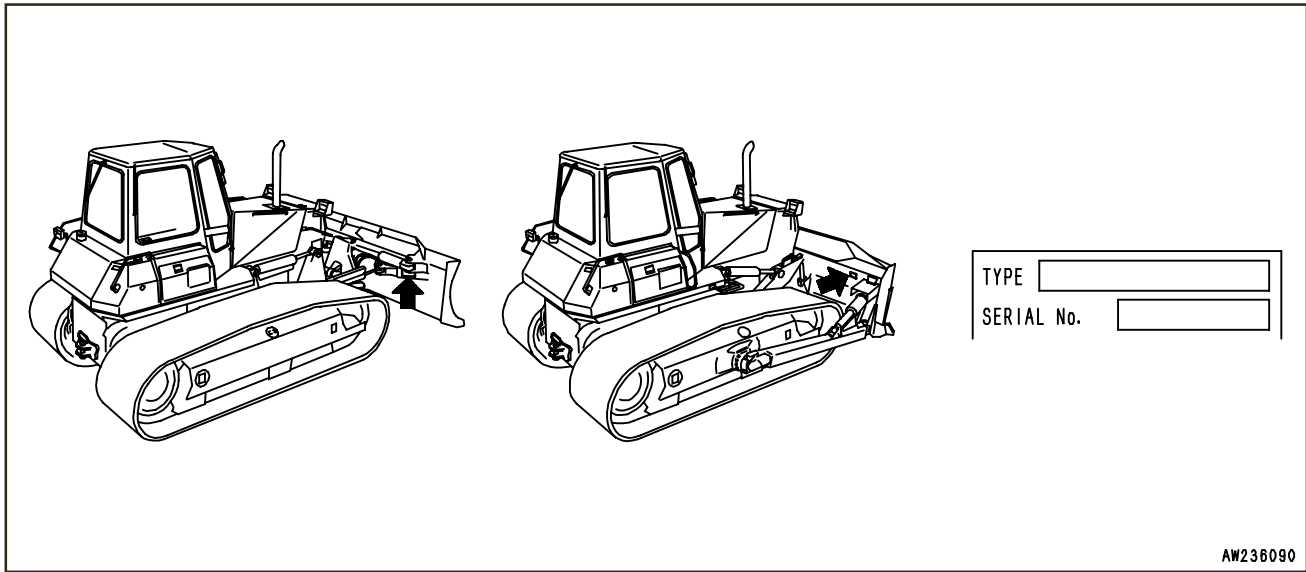

POSITION OF SERVICE METER

This is at the left upper part of the monitor panel.

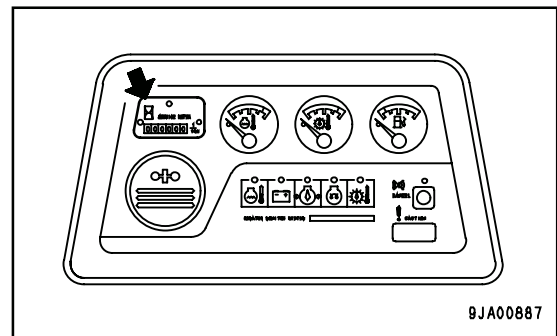

TABLE OF ENTER SERIAL NO. AND DISTRIBUTOR

Machine serial No.	
Engine serial No.	
Distributor name	
Address	-----

Service Personal	-----
Phone/Fax	-----

CONTENTS

FOREWORD

FOREWORD	1-2
SAFETY INFORMATION	1-4
INTRODUCTION	1-6
FRONT/REAR, LEFT/RIGHT DIRECTIONS OF MACHINE	1-6
NECESSARY INFORMATION	1-7
MACHINE SERIAL NO. PLATE AND POSITION	1-7
ENGINE SERIAL NO. PLATE AND POSITION	1-7
BLADE SERIAL NO. PLATE AND POSITION	1-8
POSITION OF SERVICE METER	1-8
TABLE OF ENTER SERIAL NO. AND DISTRIBUTOR	1-8

SAFETY

SAFETY	2-2
SAFETY LABELS	2-4
POSITIONS OF SAFETY PICTOGRAMS	2-4
SAFETY LABELS	2-5
GENERAL PRECAUTIONS	2-8
PRECAUTIONS FOR OPERATION	2-17
BEFORE STARTING ENGINE	2-17
AFTER STARTING ENGINE	2-19
TRANSPORTATION	2-23
BATTERY	2-24
TOWING	2-26
PRECAUTIONS FOR MAINTENANCE	2-27

OPERATION

GENERAL VIEW	3-2
GENERAL VIEW OF MACHINE	3-2
GENERAL VIEW OF CONTROLS AND GAUGES	3-3
EXPLANATION OF COMPONENTS	3-5
MONITOR PANEL	3-5
SWITCHES	3-9

LAMP	3-14
CONTROL LEVERS AND PEDALS	3-15
FUSE	3-22
ELECTRIC POWER TAKE-OUT ADAPTER	3-24
DOOR-OPEN LOCK	3-25
SASH GLASS INTERMEDIATE LOCK.....	3-25
CAP, COVER WITH LOCK.....	3-26
HOT AND COOL BOX	3-27
OPERATION MANUAL STORAGE	3-27
ASHTRAY	3-28
TOOL BOX.....	3-28
AIR CONDITIONER.....	3-29
HEATER	3-35
OPERATION	3-38
CHECK BEFORE STARTING ENGINE, ADJUST.....	3-38
STARTING ENGINE	3-54
OPERATIONS AND CHECKS AFTER STARTING ENGINE	3-59
STOPPING ENGINE.....	3-62
CHECK AFTER STOPPING ENGINE	3-63
MACHINE OPERATION	3-64
SHIFTING GAER	3-68
SHIFTING BETWEEN FORWARD AND REVERSE	3-69
STEERING MACHINE	3-71
PRECAUTIONS FOR OPERATION	3-75
WORK POSSIBLE USING BULLDOZER	3-77
ADJUSTING POSTURE OF WORK EQUIPMENT.....	3-79
PARKING MACHINE	3-81
CHECK AFTER FINISHING WORK	3-83
LOCKING.....	3-83
TIPS FOR LONGER UNDERCARRIAGE LIFE	3-84
TRANSPORTATION	3-88
TRANSPORTATION PROCEDURE	3-88
PRECAUTIONS WHEN REMOVING WORK EQUIPMENT	3-88
REMOVING CAB	3-89
LOADING, UNLOADING WORK	3-90
LIFTING MACHINE.....	3-94
COLD WEATHER OPERATION	3-97
PRECAUTIONS FOR LOW TEMPERATURE	3-97
AFTER COMPLETION OF WORK	3-99
AFTER COLD WEATHER	3-99
LONG-TERM STORAGE	3-100
BEFORE STORAGE.....	3-100
DURING STORAGE	3-100
AFTER STORAGE.....	3-100
STARTING MACHINE AFTER LONG-TERM STORAGE	3-101

TROUBLESHOOTING	3-102
AFTER RUNNING OUT OF FUEL.....	3-102
TOWING THE MACHINE	3-102
IF BATTERY IS DISCHARGED.....	3-103
OTHER TROUBLE	3-107
MAINTENANCE	
GUIDE TO MAINTENANCE	4-2
OUTLINE OF SERVICE	4-5
OUTLINE OF OIL, FUEL, COOLANT	4-5
RELATING TO ELECTRIC SYSTEM	4-7
WEAR PARTS	4-8
WEAR PARTS LIST.....	4-8
USE OF FUEL, COOLANT AND LUBRICANTS ACCORDING TO AMBIENT TEMPERATURE	4-9
PROPER SELECTION OF FUEL, COOLANT AND LUBRICANTS	4-9
STANDARD TIGHTENING TORQUES FOR BOLTS AND NUTS	4-13
TORQUE LIST	4-13
PERIODIC REPLACEMENT OF SAFETY CRITICAL PARTS	4-14
SAFETY CRITICAL PARTS.....	4-15
MAINTENANCE SCHEDULE CHART	4-16
MAINTENANCE SCHEDULE CHART	4-16
SERVICE PROCEDURE	4-18
WHEN REQUIRED.....	4-18
CHECK BEFORE STARTING	4-39
EVERY 50 HOURS SERVICE	4-40
EVERY 250 HOURS SERVICE	4-41
EVERY 500 HOURS SERVICE	4-48
EVERY 1000 HOURS SERVICE	4-51
EVERY 2000 HOURS SERVICE	4-56
EVERY 4000 HOURS SERVICE	4-58

SPECIFICATIONS

SPECIFICATIONS	5-2
-----------------------------	-----

ATTACHMENTS, OPTIONS

GENERAL PRECAUTIONS	6-2
PRECAUTIONS RELATED TO SAFETY	6-2
SUSPENSION SEAT	6-3
HEADREST	6-4
EQUIPPING THE FIRE EXTINGUISHER AND THE FIRST-AID KIT	6-5
INDEX	7-1

SAFETY

 **WARNING**

Please be sure that you fully understand this manual and the precautions related to safety for the machine. When operating or servicing the machine, always follow these precautions strictly.

SAFETY

SAFETY LABELS.....	2-4
POSITIONS OF SAFETY PICTOGRAMS	2-4
SAFETY LABELS.....	2-5
GENERAL PRECAUTIONS.....	2-8
SAFETY RULES	2-8
IF ABNORMALITIES ARE FOUND	2-8
CLOTHING AND PERSONAL PROTECTIVE ITEMS	2-8
FIRE EXTINGUISHER AND FIRST AID KIT	2-8
SAFETY FEATURES.....	2-9
KEEP MACHINE CLEAN.....	2-9
INSIDE OPERATOR'S COMPARTMENT.....	2-9
ALWAYS APPLY L LOCK WHEN LEAVING OPERATOR'S SEAT	2-9
HANDRAILS AND STEPS	2-10
MOUNTING AND DISMOUNTING	2-11
NO PEOPLE ON ATTACHMENTS.....	2-11
PREVENTION OF BURNS	2-11
FIRE PREVENTION	2-12
ACTION IF FIRE OCCURS	2-13
WINDOW WASHER LIQUID	2-13
PRECAUTIONS WHEN USING ROPS (Roll Over Protective Structure).....	2-13
PRECAUTIONS FOR ATTACHMENTS	2-13
UNAUTHORIZED MODIFICATION	2-13
SAFETY AT WORKSITE	2-14
WORKING ON LOOSE GROUND.....	2-14
DO NOT GO CLOSE TO HIGH-VOLTAGE CABLES.....	2-15
ENSURE GOOD VISIBILITY	2-15
VENTILATION FOR ENCLOSED AREAS.....	2-16
CHECKING SIGNALMAN'S SIGNALS AND SIGNS	2-16
BE CAREFUL ABOUT ASBESTOS DUST.....	2-16

PRECAUTIONS FOR OPERATION	2-17
BEFORE STARTING ENGINE	2-17
CHECKS BEFORE STARTING ENGINE	2-17
PRECAUTIONS WHEN STARTING	2-18
PRECAUTIONS IN COLD AREAS	2-18
AFTER STARTING ENGINE	2-19
CHECKS AFTER STARTING ENGINE	2-19
PRECAUTIONS FOR MOVING MACHINE FORWARD OR IN REVERSE	2-19
PRECAUTIONS WHEN TRAVELING	2-20
TRAVELING ON SLOPES	2-21
PROHIBITED OPERATIONS	2-21
USING BRAKES	2-21
OPERATE CAREFULLY ON SNOW	2-22
PARKING MACHINE	2-22
TRANSPORTATION	2-23
LOADING AND UNLOADING	2-23
SHIPPING	2-23
BATTERY	2-24
BATTERY HAZARD PREVENTION	2-24
STARTING WITH BOOSTER CABLE	2-25
TOWING	2-26
WHEN TOWING	2-26
PRECAUTIONS FOR MAINTENANCE	2-27
WARNING TAG	2-27
KEEP WORK PLACE CLEAN AND TIDY	2-27
APPOINT LEADER WHEN WORKING WITH OTHERS	2-27
STOP ENGINE BEFORE CARRYING OUT INSPECTION AND MAINTENANCE	2-28
TWO WORKERS FOR MAINTENANCE WHEN ENGINE IS RUNNING	2-29
PROPER TOOLS	2-29
PERSONNEL	2-29
ATTACHMENTS	2-30
PRECAUTIONS FOR WORK UNDER MACHINE AND WORK EQUIPMENT	2-30
NOISE	2-30
PRECAUTIONS WHEN USING HAMMER	2-30
REPAIR WELDING	2-31
REMOVING BATTERY TERMINAL	2-31
PRECAUTIONS WHEN USING HIGH-PRESSURE GREASE TO ADJUST TRACK TENSION	2-31
DO NOT DISASSEMBLE RECOIL SPRING	2-31
PRECAUTION WITH HIGH-PRESSURE OIL	2-32
HANDLING HIGH-PRESSURE HOSES	2-32
WASTE MATERIAL	2-32
MAINTENANCE FOR AIR CONDITIONER	2-33
COMPRESSED AIR	2-33
PERIODIC REPLACEMENT OF SAFETY CRITICAL PARTS	2-33

SAFETY LABELS

The following warning signs and safety labels are used on this machine.

- Be sure that you fully understand the correct position and content of labels.
- To ensure that the content of labels can be read properly. Be sure that they are in the correct place and always keep them clean. When cleaning them, do not use organic solvents or gasoline, there may cause the labels to peel off.
- There are also other labels in addition to the warning signs and safety labels. Handle those labels in the same way.
- If the labels are damaged, lost, or cannot be read properly, replace them with new ones. For details of the part numbers for the labels, see this manual or the actual label, and place an order with Komatsu distributor.

POSITIONS OF SAFETY PICTOGRAMS

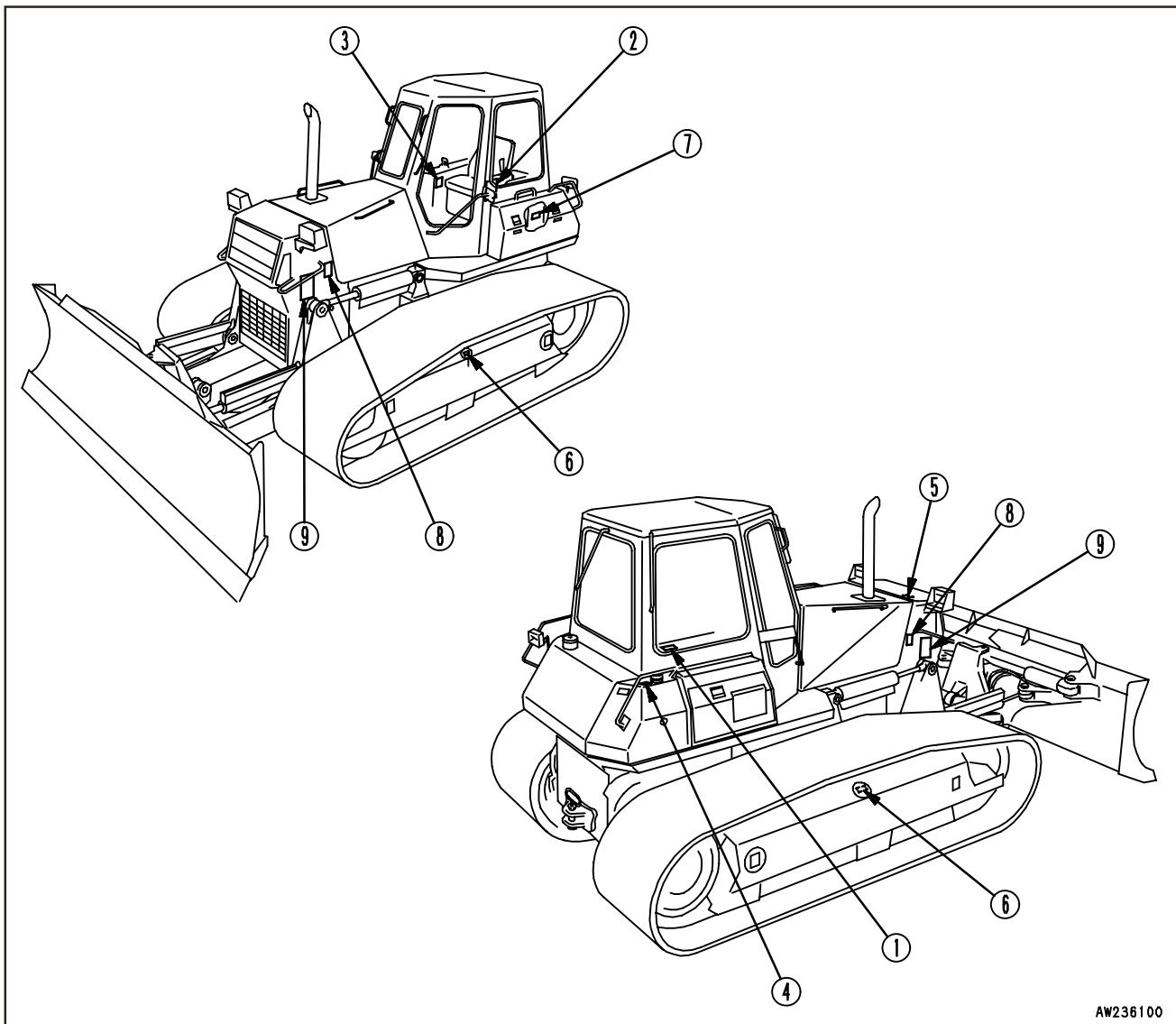

SAFETY LABELS

- (1) Precautions for operation, inspection and maintenance (09651-A0641)

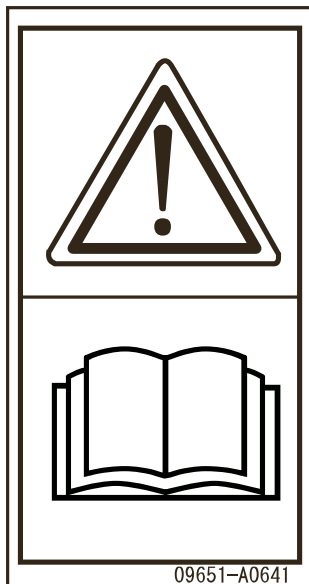

Warning sign.

Read the Operation and Maintenance Manual before operating, maintaining, carrying out disassembly, assembly or transportation of this machine.

- (2) Precautions when traveling in reverse (09802-13000)

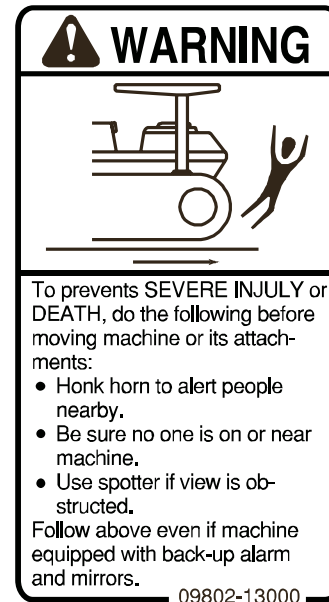

To prevent SEVERE INJURY or DEATH, do the following before moving machine or its attachments:

- Honk horn to alert people nearby.
- Be sure no one is on or near machine.
- Use spotter if view is obstructed.

Follow above even if machine equipped with back-up alarm and mirrors.

- (3) Precautions for leaving the operator's seat (09654-B0641)



There is the hazard that machine may move suddenly and catch or run over someone near the machine causing injury.

When leaving the machine, always lower the work equipment completely to the ground, place the control levers in LOCK position, stop the engine and remove the key and take it with you.

- (4) Precautions for high-temperature hydraulic oil (09653-A0481)



Never remove the cap when the engine is at operating (high) temperature. Steam or high temperature oil blowing up from the radiator or hydraulic tank, will cause personal injury and/or burns.

Never remove the radiator cap or hydraulic tank oil filler when cooling water or hydraulic oil is at high temperatures.

- (5) Precautions for high-temperature cooling water (09653-A0481)



Never remove the cap when the engine is at operating (high) temperature. Stream or high temperature oil blowing up from the radiator or hydraulic tank, will cause personal injury and/or burns.

Never remove the radiator cap or hydraulic tank oil filler when cooling water or hydraulic oil is at high temperatures.

- (6) Precautions for check and adjust track tension (09657-A0881)

Safety label is attached on the back side of the inspection cover of the track frame.

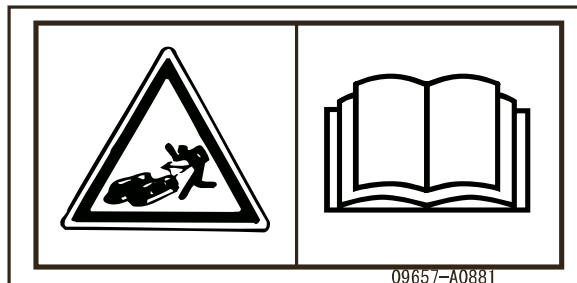

Plug coming from track shoe tension adjustment device causing injury.

Read the operation and maintenance manual and carrying out the correct method when loosening track tension.

- (7) Precautions for handling electric wires (09808-A0881)

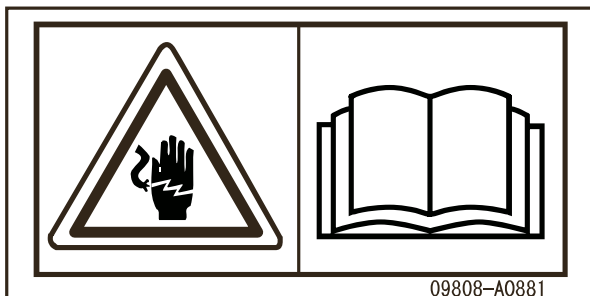

There is the hazard to electric shock when handling electric wires.

Read the operation and maintenance manual and carrying out the correct method when handling.

- (8) Caution for engine running (09667-A0641)

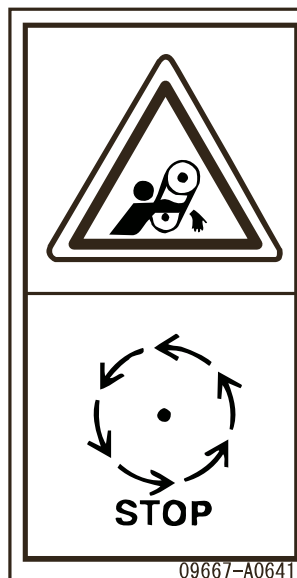

There is the hazard of being caught in the rotating parts of the machine causing injury.

Stop the rotating parts of the machine completely when carrying out inspection and maintenance.

- (9) Caution for approach when machine moving
(09806-B1201)

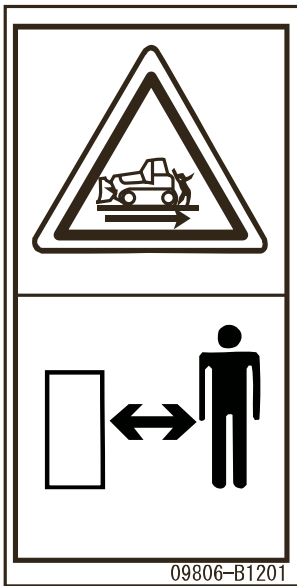

There is danger of getting hit and injured by approach when machine moving.

Do not go close to machine.

GENERAL PRECAUTIONS

SAFETY RULES

- Only trained and authorized personnel can operate and maintain the machine.
- Follow all safety rules, precautions and instructions when operating or performing maintenance on the machine.
- If you are under the influence of alcohol or medication, your ability to safely operate or repair your machine may be severely impaired putting yourself and everyone else on your jobsite in danger.
- When working with another operator or with a person on worksite traffic duty, be sure that all personnel understand all hand signals that are to be used.

IF ABNORMALITIES ARE FOUND

If you find any abnormality in the machine during operation or maintenance (noise, vibration, smell, incorrect gauges, smoke, oil leakage, etc., or any abnormal display on the warning devices or monitor), report to the person in charge and have the necessary action taken. Do not operate the machine until the abnormality has been corrected.

CLOTHING AND PERSONAL PROTECTIVE ITEMS

- Do not wear loose clothing and accessories. There is a hazard that they may catch on control levers or other protruding parts.
- If you have long hair and it hangs out from your hard hat, there is a hazard that it may get caught up in the machine, so tie your hair up and be careful not to let it get caught.
- Always wear a hard hat and safety shoes. If the nature of the work requires it, wear safety glasses, mask, gloves, ear plugs, and safety belt when operating or maintaining the machine.
- Check that all protective equipment functions properly before using it.

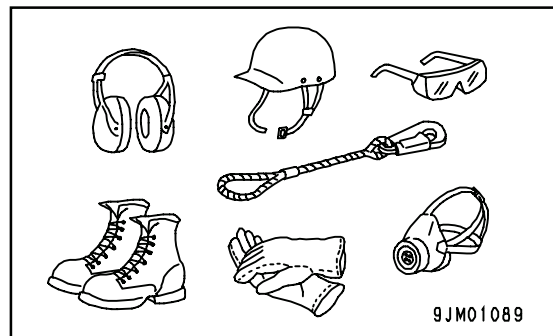

FIRE EXTINGUISHER AND FIRST AID KIT

Always follow the precautions below to prepare for action if any injury or fire should occur.

- Be sure that fire extinguishers have been provided and read the labels to ensure that you know how to use them in emergencies.
- Carry out periodic inspection and maintenance to ensure that the fire extinguisher can always be used.
- Provide a first aid kit at the storage point. Carry out periodic checks and add to the contents if necessary.

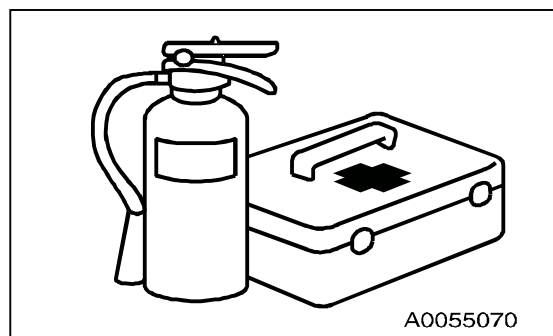

SAFETY FEATURES

- Be sure that all guards and covers are in their proper position. Have guards and covers repaired immediately if they are damaged.
- Understand the method of use of safety features and use them properly.
- Never remove any safety features. Always keep them in good operating condition.

KEEP MACHINE CLEAN

- If water gets into the electrical system, there is a hazard that it will cause malfunctions or misoperation. Do not use water or steam to wash the electrical system (sensors, connectors).
- If inspection and maintenance is carried out when the machine is still dirty with mud or oil, there is a hazard that you will slip and fall, or that dirt or mud will get into your eyes. Always keep the machine clean.

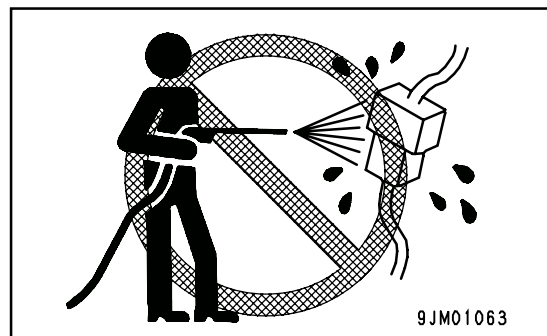

INSIDE OPERATOR'S COMPARTMENT

- When entering the operator's compartment, always remove all mud and oil from the soles of your shoes. If you operate the pedal with mud or oil affixed to your shoes, your foot may slip and this may cause a serious accident.
- Do not leave parts or tools lying around the operator's compartment.
- Do not stick suction pads to the window glass. Suction pads act as a lens and may cause fire.
- Do not use cellular telephones inside the operator's compartment when driving or operating the machine.
- Never bring any dangerous objects such as flammable or explosive items into the operator's cab.

ALWAYS APPLY LOCK WHEN LEAVING OPERATOR'S SEAT

- Before standing up from the operator's seat (such as when adjusting the operator's seat), lower the work equipment completely to the ground, set safety lock lever(1) and brake lock lever(2) securely to the LOCK position, then stop the engine. If you accidentally touch the levers when they are not locked, there is a hazard that the machine may suddenly move and cause serious injury or property damage.
- When leaving the machine, always lower the work equipment completely to the ground, set safety lock lever(1) and brake lock lever(2) securely to the LOCK position, then stop the engine. Use the key to lock all the equipment. Always remove the key, take it with you, and keep it in the specified place.

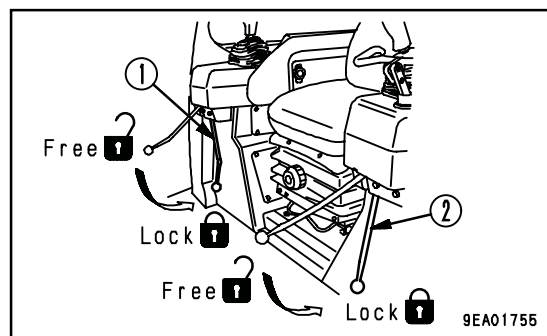

HANDRAILS AND STEPS

To prevent personal injury caused by slipping or falling off the machine, always do as follows.

- Use the handrails and steps marked by arrows in the diagram on the right when getting on or off the machine.

For power angle, power tiltdozer

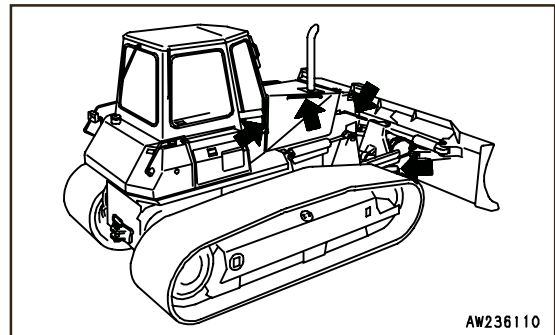
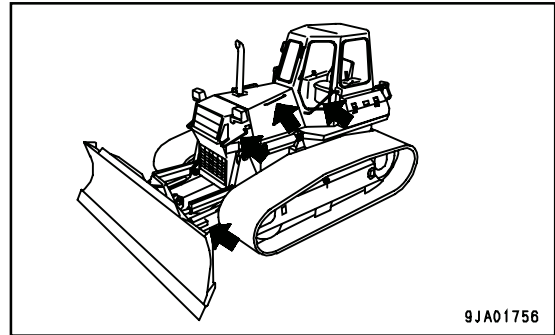

For power tiltdozer

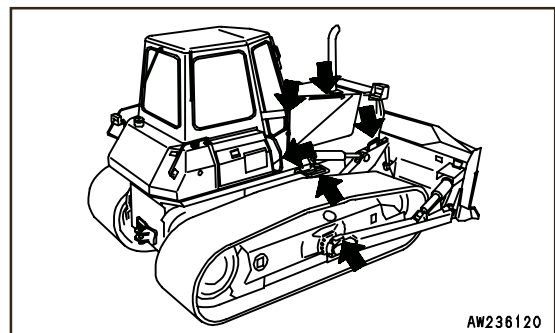
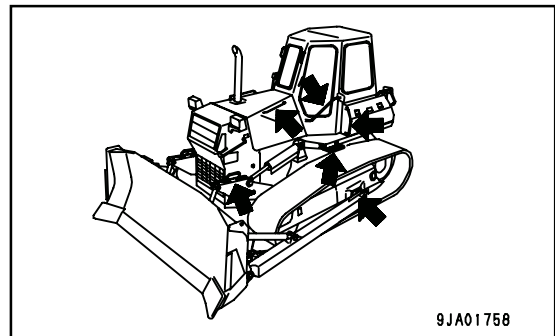

SAFETY**GENERAL PRECAUTIONS**

- To ensure safety, always face the machine and maintain three-point contact (both feet and one hand, or both hands and one foot) with the handrails and steps (including the track shoe) to ensure that you support yourself.
- Do not grip the control levers when getting on or off the machine.
- Never climb on the engine hood or covers where there are no non-slip pads.

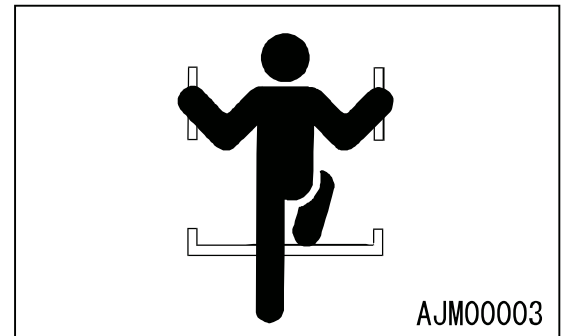

- Before getting on or off the machine, check the handrails and steps (including the track shoe). If there is any oil, grease, or mud on the handrails or steps (including the track shoe), wipe it off immediately. Always keep these parts clean. Repair any damage and tighten any loose bolts.
- Do not get on or off the machine while holding tools in your hand.

MOUNTING AND DISMOUNTING

- Never jump on or off the machine. Never get on or off a moving machine.
- If the machine starts to move when there is no operator on the machine, do not jump on to the machine and try to stop it.

NO PEOPLE ON ATTACHMENTS

Never let anyone ride on the attachments. There is a hazard of falling and suffering serious injury.

PREVENTION OF BURNS**Hot coolant**

- To prevent burns from hot water or steam spurting out when checking or draining the coolant, wait for the water to cool to a temperature where it is possible to touch the radiator cap by hand before starting the operation. Even when the coolant has cooled down, loosen the cap slowly to relieve the pressure inside the radiator before removing the cap.

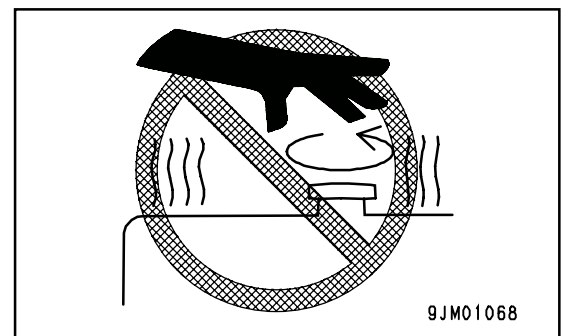
**Hot oil**

- To prevent burns from hot oil or other parts when checking or draining the oil, wait for the oil to cool to a temperature where it is possible to touch the cap by hand before starting the operation. Even when the oil has cooled down, loosen the plug slowly to relieve the internal pressure before removing the plug.

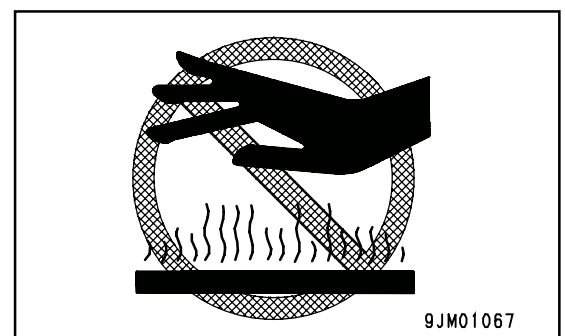

FIRE PREVENTION

● Fire caused by fuel or oil

Fuel, oil, antifreeze, and window washer liquid are particularly flammable and can be hazardous. To prevent fire, always observe the following:

- Do not smoke or use any flame near fuel or oil.
 - Stop the engine before refueling.
 - Do not leave the machine while adding fuel or oil.
 - Tighten all fuel and oil caps securely.
 - Do not spill fuel on overheated surfaces or on parts of the electrical system.
 - Use well-ventilated areas for adding or storing oil and fuel.
 - Keep oil and fuel in the determined place and do not allow unauthorized persons to enter.
 - After adding fuel or oil, wipe up any spilled fuel or oil.
 - When carrying out grinding or welding work on the chassis, move any flammable materials to a safe place before starting.
 - When washing parts with oil, use a non-flammable oil. Diesel oil and gasoline may catch fire, so do not use them.
 - Put greasy rags and other flammable materials into a safe container to maintain safety at the work place.
 - Do not weld or use a cutting torch to cut any pipes or tubes that contain flammable liquids.
-
- **Fire caused by accumulation of flammable material.**
 - Remove any dry leaves, chips, pieces of paper, dust, or any other flammable materials accumulated or affixed around the engine, exhaust manifold, muffler, or battery, or inside the undercovers.
 - **Fire coming from electric wiring**

Short circuits in the electrical system can cause fire.

 - Always keep electric wiring connections clean and securely tightened.
 - Check the wiring every day for looseness or damage. Tighten any loose connectors or wiring clamps. Repair or replace any damaged wiring.
 - **Fire coming from hydraulic line**

Check that all the hose and tube clamps, guards, and cushions are securely fixed in position. If they are loose, they may vibrate during operation and rub against other parts. This may lead to damage to the hoses, and cause high-pressure oil to spurt out, leading to fire damage or serious injury.
 - **Explosion caused by lighting equipment**
 - When checking fuel, oil, battery electrolyte, window washer fluid, or coolant, use explosion-proof lighting. If you do not use explosion-proof lighting, there is a hazard of serious injury or damage caused by explosion.
 - When taking the electrical power for the lighting from the machine, follow the instructions in this manual.

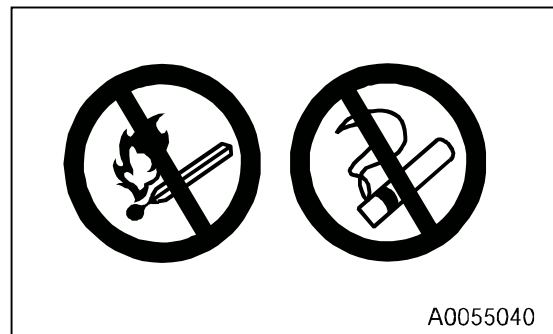

ACTION IF FIRE OCCURS

If a fire occurs, escape from the machine as follows.

- Turn the starting switch OFF and stop the engine.
- Use the handrails and steps to get off the machine.

WINDOW WASHER LIQUID

Use an ethyl alcohol base washer liquid. Methyl alcohol base washer liquid may irritate your eyes, so do not use it.

PRECAUTIONS WHEN USING ROPS (Roll Over Protective Structure)

Install ROPS when working in places where there is danger of falling rocks, such as in mines and quarries, or in places where there is danger of rolling over.

- If ROPS is installed, do not remove it when operating the machine.
- ROPS is installed to protect the operator when machine rolls over. When machine rolls over, ROPS supports its weight and absorbs its impact energy.
- If ROPS is modified, its strength may lower. When modifying it, consult your Komatsu distributor.
- If ROPS is deformed by falling objects or by rolling over, its strength lowers and its design functions cannot be maintained. In this case, be sure to ask your Komatsu distributor about repair method.
- Even if ROPS is installed, it does not work normally, if your seat belt is not fastened. Be sure to fasten your seat belt when operating machine.

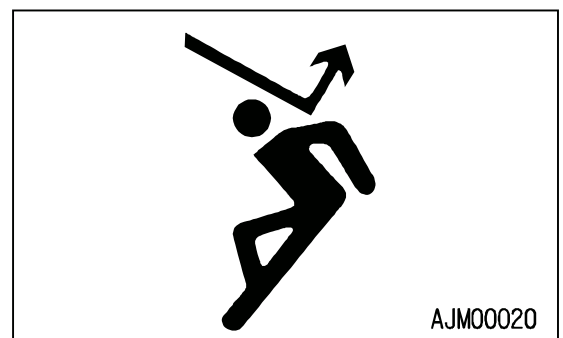

PRECAUTIONS FOR ATTACHMENTS

- When installing optional parts or attachments, there may be problems with safety or legal restrictions, so please contact your Komatsu distributor for advice.
- Any injuries, accidents, or product failures resulting from the use of unauthorized attachments or parts will not be the responsibility of Komatsu.
- When installing and using optional attachments, read the instruction manual for the attachment, and the general information related to attachments in this manual.

UNAUTHORIZED MODIFICATION

Any modification made without authorization from Komatsu can create hazards. Before making a modification, consult your Komatsu distributor.

- Komatsu will not be responsible for any injuries, accidents, or product failures resulting from modifications made without authorization from Komatsu.

SAFETY AT WORKSITE

Before starting operations, thoroughly check the area for any unusual conditions that could be dangerous.

- When carrying out operations near combustable materials such as thatched roofs, dry leaves or dry grass, there is a hazard of fire, so be careful when operating.
- Check the terrain and condition of the ground at the worksite, and determine the safest method of operation. Do not carry out operations at places where there is a hazard of landslides or falling rocks.
- If water lines, gas lines, or high-voltage electrical lines may be buried under the worksite, contact each utility and identify their locations. Be careful not to sever or damage any of these lines.
- Take necessary measures to prevent any unauthorized person from entering the operating area.
- In particular, if you need to operate on a road, protect pedestrian and cars by designating a person for worksite traffic duty or by installing fences around the worksite.
- When traveling or operating in shallow water or on soft ground, check the shape and condition of the bedrock, and the depth and speed of flow of the water before starting operations.

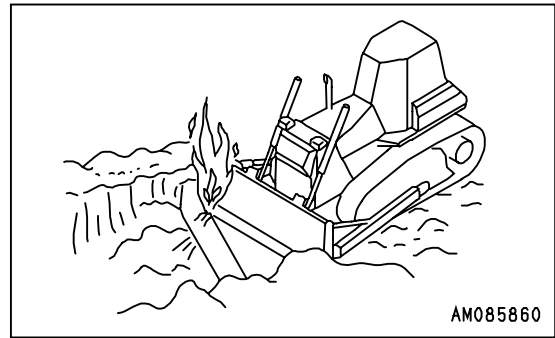

WORKING ON LOOSE GROUND

- Avoid traveling or operating your machine too close to the edge of cliffs, overhangs, and deep ditches. The ground may be weak in such areas. If the ground should collapse under the weight or vibration of the machine, there is a hazard that the machine may fall or tip over. Remember that the soil after heavy rain or blasting or after earthquakes is weak in these areas.
- When working on embankments or near excavated ditches, there is a hazard that the weight and vibration of the machine will cause the soil to collapse. Before starting operations, take steps to ensure that the ground is safe and to prevent the machine from rolling over or falling.

DO NOT GO CLOSE TO HIGH-VOLTAGE CABLES

Do not travel or operate the machine near electric cables. There is a hazard of electric shock, which may cause serious injury or property damage. On jobsites where the machine may go close to electric cables, always do as follows.

- Before starting work near electric cables, inform the local power company of the work to be performed, and ask them to take the necessary action.
- Even going close to high-voltage cables can cause electric shock, which may cause serious burns or even death. Always maintain a safe distance (see the table on the right) between the machine and the electric cable. Check with the local power company about safe operating procedure before starting operations.
- To prepare for any possible emergencies, wear rubber shoes and gloves. Lay a rubber sheet on top of the seat, and be careful not to touch the chassis with any exposed part of your body.
- Use a signalman to give warning if the machine approaches too close to the electric cables.
- When carrying out operations near high voltage cables, do not let anyone come close to the machine.
- If the machine should come too close or touch the electric cable, to prevent electric shock, the operator should not leave the operator's compartment until it has been confirmed that the electricity has been shut off. Also, do not let anyone come close to the machine.

	Voltage	Min. safety distance
Low voltage	100V 200V	2m
	6,600V	2m
Very high voltage	22,000V	3m
	66,000V	4m
	154,000V	5m
	187,000V	6m
	275,000V	7m
	500,000V	11m

ENSURE GOOD VISIBILITY

- Check for any persons or obstacles in the area around the machine and check the conditions of the jobsite to ensure that operations and travel can be carried out safely. Always do as follows.
 - Position a signalman if there are areas at the rear of the machine where the visibility is not good.
 - When working in dark places, turn on the working lamp and front lamps installed to the machine, and set up additional lighting in the work area if necessary.
 - Stop operations if the visibility is poor, such as in mist, snow, rain, or dust.

VENTILATION FOR ENCLOSED AREAS

Exhaust fumes from the engine can kill.

- If it is necessary to start the engine within an enclosed area, or when handling fuel, flushing oil, or paint, open the doors and windows to ensure that you provide adequate ventilation is provided to prevent gas poisoning.

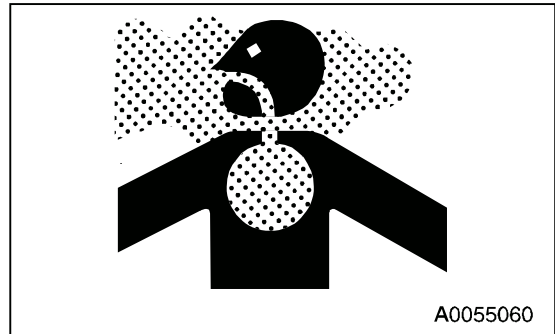

A0055060

CHECKING SIGNALMAN'S SIGNALS AND SIGNS

- Set up signs to inform of road shoulders and soft ground. If the visibility is not good, position a signalman if necessary. Operators should pay careful attention to the signs and follow the instructions from the signalman.
- Only one signalman should give signals.
- Make sure that all workers understand the meaning of all signals and signs before starting work.

BE CAREFUL ABOUT ASBESTOS DUST

Asbestos dust in the air can cause lung cancer if it is inhaled. There is danger of inhaling asbestos when working on jobsites handling demolition work or work handling industrial waste. Always observe the following.

- Spray water to keep down the dust when cleaning. Do not use compressed air for cleaning.
- If there is danger that there may be asbestos dust in the air, always operate the machine from an upwind position. All workers should use an approved respirator.
- Do not allow other persons to approach during the operation.
- Always observe the rules and regulations for the work site and environmental standards.

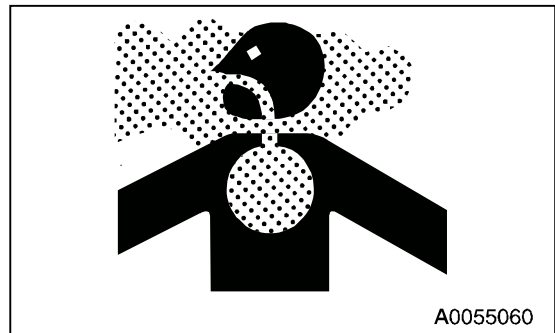

A0055060

This machine does not use asbestos, but there is a danger that imitation parts may contain asbestos, so always use genuine Komatsu parts.

PRECAUTIONS FOR OPERATION

BEFORE STARTING ENGINE

If there is a warning tag hanging from the work equipment control lever, do not start the engine or touch the levers (1).

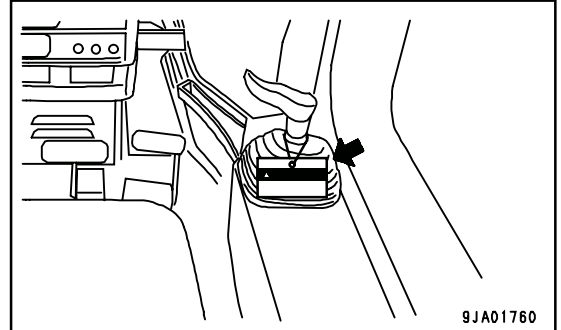

CHECKS BEFORE STARTING ENGINE

Carry out the following checks before starting the engine at the beginning of the day's work.

- Remove all dirt from the surface of the window glass to ensure a good view.
- Remove all dirt from the surface of the lens of the front lamps and working lamps, and check that they light up correctly.
- Check the coolant level, fuel level, and oil level in engine oil pan, check for clogging of the air cleaner, and check for damage to the electric wiring.
- Adjust the operator's seat to a position where it is easy to carry out operations, and check that there is no damage or wear to the seat belt or mounting clamps.
- Check that the gauges work properly, check the angle of the lights and working lamps, and check that the control levers are all at the neutral position.
- Check that there are no persons or obstacles above, below, or in the area around the machine.

PRECAUTIONS WHEN STARTING

- When starting the engine, sound the horn as a warning.
- Start and operate the machine only while seated.
- Do not allow anyone apart from the operator to ride on the machine.
- Do not short circuit the starting motor circuit to start the engine. It is not only dangerous, but will also cause damage to the equipment.

PRECAUTIONS IN COLD AREAS

- Carry out the warming-up operation thoroughly. If the machine is not thoroughly warmed up before the control levers are operated, the reaction of the machine will be slow, and this may lead to unexpected accidents.
- If the battery electrolyte is frozen, do not charge the battery or start the engine with a different power source. There is a hazard that this will ignite the battery. Before charging or starting the engine with a different power source, melt the battery electrolyte and check for frost and leakage of battery electrolyte before starting.

AFTER STARTING ENGINE

CHECKS AFTER STARTING ENGINE

When carrying out the checks, move the machine to a wide area where there are no obstructions, and operate slowly. Do not allow anyone near the machine.

- Always fasten your seat belt.
- Check the actuating condition of the work equipment, travel, and brake systems.
- Check for any abnormality in the sound of the machine, vibration, heat, smell, or gauges; check also that there is no leakage of oil or fuel.
- If any abnormality is found, carry out repairs immediately.

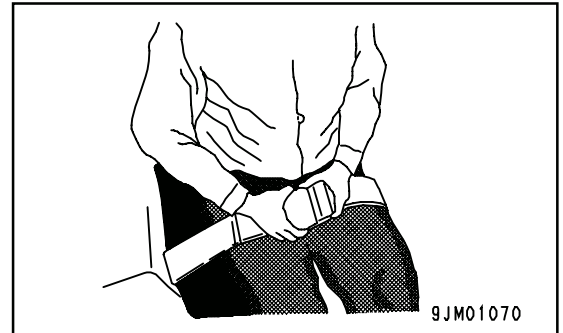

PRECAUTIONS FOR MOVING MACHINE FORWARD OR IN REVERSE

- Before travelling, check again that there is no one in the surrounding area, and that there are no obstacles.
- Before travelling, sound the horn to warn people in the area.
- Always operate the machine only when seated.
- Do not allow anyone apart from the operator to ride on the machine.
- Check that the back-up alarm (alarm buzzer when machine travels in reverse) works properly.
- Fix the operator's compartment doors and windows in position securely.

Always be sure to carry out the above precautions even when the machine is equipped with mirrors.

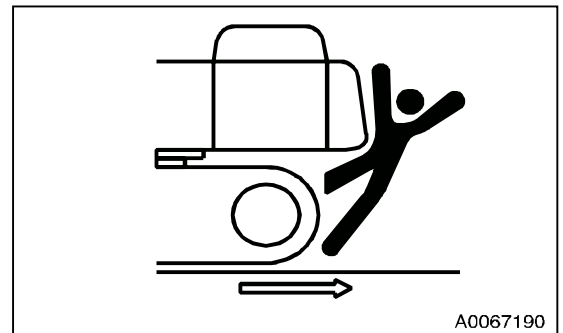

PRECAUTIONS WHEN TRAVELING

- Never turn the key in the starting switch to the OFF position when traveling. If the engine stops during travel, the machine stops suddenly, and that is dangerous.
- When traveling on flat ground, pull the work equipment and keep its height at 40 to 50cm (16 to 20in) above the ground.
- When traveling on rough ground, travel at low speed and do not operate the steering suddenly. There is danger that the machine may turn over. The work equipment may hit the ground surface and cause the machine to lose its balance, or may damage the machine or structures in the area.

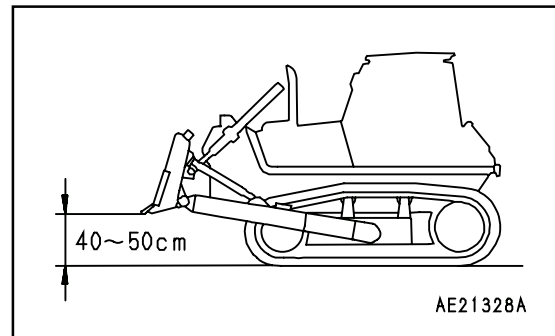

- Avoid traveling over obstacles when possible. If the machine has to travel over an obstacle, keep the work equipment close to the ground and travel at low speed. Never travel over obstacles which make the machine tilt strongly to one side.
- When traveling or carrying out operations, always keep a safe distance from people, structures, or other machines to avoid coming into contact with them.
- When passing over bridges or structures, check first that the structure is strong enough to support the weight of the machine. When traveling on public roads, check first with the relevant authorities and follow their instructions.
- When operating in tunnels, under bridges, under electric wires, or other places where the height is limited, operate slowly and be extremely careful not to let the work equipment hit anything.
- Do not approach the edge of a cliff carelessly. When dropping soil over a cliff for banking or reclamation, leave soil of one scoop at the edge of the cliff and push it with the next scoop.
- When the machine passes over the top of a hill or when a load is dumped over a cliff, the load is suddenly reduced, and there is danger that the travel speed rises suddenly. To prevent this, lower the travel speed.
- If the machine moves with only either side of the blade loaded, its tail may swing. Take care.

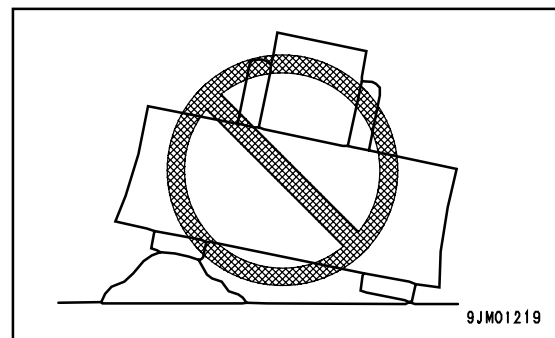

TRAVELING ON SLOPES

To prevent the machine from tipping over or slipping to the side, always do as follows.

- When traveling on slopes, keep the blade approximately 20 to 30cm (8 to 12in) above the ground. In case of emergency, quickly lower the blade to the ground to help the machine to stop. Apply the brake and use the engine as a brake, if necessary.
- Always travel straight up or down a slope. Traveling at an angle or across the slope is extremely dangerous.
- Do not turn on slopes or travel across slopes. Always go down to a flat place to change the position of the machine, then travel on to the slope again.

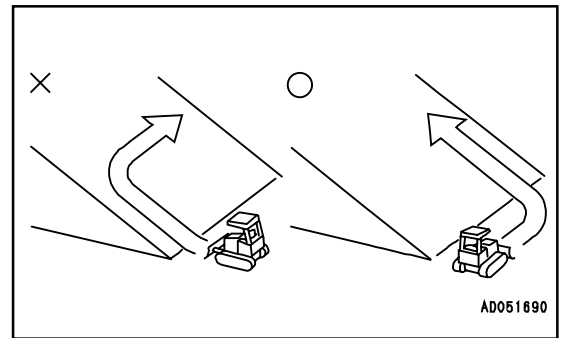

- Travel on grass, fallen leaves, or wet steel plates with low speed. Even with slight slopes there is a hazard that the machine may slip.
- Do not shift the gear while traveling downhill or travel downhill with the transmission in neutral. If this is neglected, the engine does not work as a brake, and that is dangerous. Be sure to set the transmission in one of the lower gear speeds. In addition, apply the brake and use the engine as a brake, if necessary.
- When turning on a downhill ground, lower the travel speed.
- On a slope where the machine travels down by itself, take care of countersteering.

PROHIBITED OPERATIONS

- To make it easier to escape if there is any problem, set the trackes at right angles to the road shoulder or cliff with the sprocket at the rear when carrying out digging operations.
- When operating the machine, take care that it will not exceed its performance values such as stability, maximum using load, etc. to prevent rolling of the machine caused by an overload and disasters caused by breakage of the work equipment.

USING BRAKES

- When the machine is traveling, do not rest your foot on the brake pedal. If you travel with your foot resting on the pedal, the brake will always be applied, and this will cause the brakes to overheat and fail.
- Do not depress the brake pedal repeatedly if not necessary. If this is neglected, the brake will be overheated and will not work when required.
- When traveling downhill, use the braking force of the engine. If necessary, use the brake pedal at the same time.

OPERATE CAREFULLY ON SNOW

- Snow-covered or frozen surfaces are slippery, so be extremely careful when traveling or operating the machine, and do not operate the levers suddenly. Even a slight slope may cause the machine to slip, so be particularly careful when working on slopes.
- With frozen ground surfaces, the ground becomes soft when the temperature rises, and this may cause the machine to tip over.
- If the machine enters deep snow, there is a hazard that it may tip over or become buried in the snow. Be careful not to leave the road shoulder or to get trapped in a snow drift.
- When clearing snow, the road shoulder and objects placed beside the road are buried in the snow and cannot be seen. There is a hazard of the machine tipping over or hitting covered objects, so always carry out operations carefully.
- When traveling on snow-covered slopes, never apply the brakes suddenly. Reduce the speed and use the engine as a brake while applying the foot brake intermittently (depress the brake intermittently several times). If necessary, lower the blade to the ground to stop the machine.

PARKING MACHINE

- Park the machine on firm, level ground.
- Select a place where there is no hazard of falling rocks or landslides, or of flooding if the land is low.
- Lower the work equipment completely to the ground.
- When leaving the machine, set the steering, directional and gear shift levers in the N(Neutral) position and set the blade lever in the holding position, then apply safety lock lever(1) and brake lock lever(2) and stop the engine.
- Always close the operator's cab door, and use the key to lock all the equipment in order to prevent any unauthorized person from moving the machine. Always remove the key, take it with you, and leave it in the specified place.
- If it is necessary to park the machine on a slope, always do as follows.
 - Set the blade on the downhill side, then dig it into the ground.
 - Put blocks under the tracks to prevent the machine from moving.

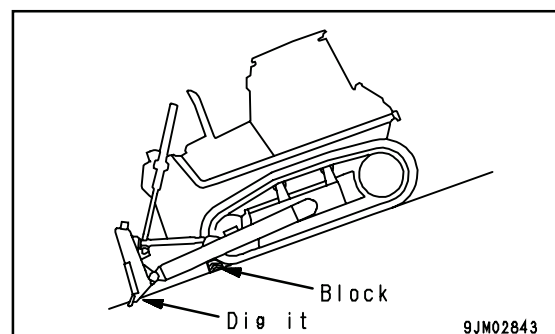
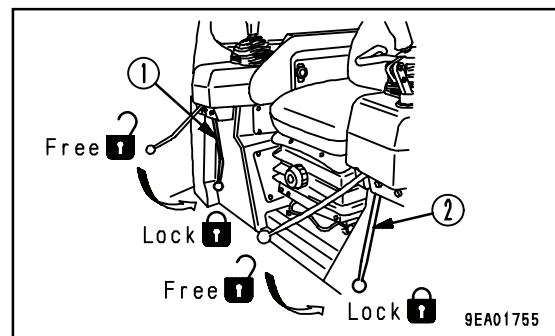
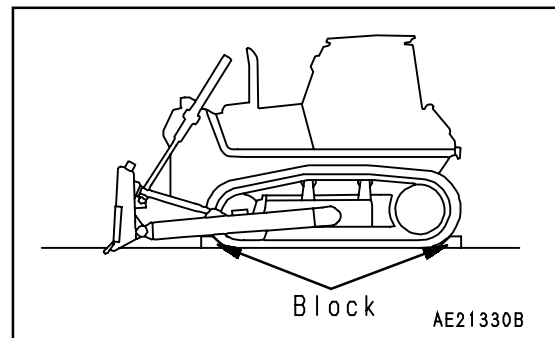

TRANSPORTATION

LOADING AND UNLOADING

When loading or unloading the machine, mistaken operation may bring the hazard of the machine tipping over or falling, so particular care is necessary. Always do as follows.

- Perform loading and unloading on firm, level ground only. Maintain a safe distance from the edge of the road or cliff.
- Always use ramps of adequate strength. Be sure that the ramps are wide, long, and thick enough to provide a safe loading slope. Take suitable steps to prevent the ramps from moving out of position or coming off.
- Be sure the ramp surface is clean and free of grease, oil, ice and loose materials. Remove dirt from machine-tracks. On a rainy day, in particular, take extremely careful since the ramp surface is slippery.
- Run the engine at low idling, set to low speed, and operate the machine slowly when loading or unloading.
- When on the ramps, do not operate any lever except for the travel lever.
- Never correct your steering on the ramps. If necessary, drive off the ramps, correct the direction, then enter the ramps again.
- The center of gravity of the machine will change suddenly at the joint between the ramps and the track or trailer, and there is danger of the machine losing its balance. Travel slowly over this point.
- When loading or unloading to an embankment or platform, make sure that it has suitable width, strength, and grade.
- For machines equipped with a cab, always lock the door after loading the machine. If this is not done, the door may suddenly open during transportation.

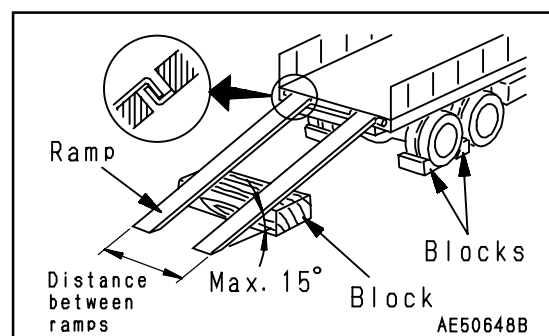

SHIPPING

When shipping the machine on a trailer, do as follows.

- Investigate all state and local laws governing the weight, width, and length of a load. If necessary, disassemble the work equipment. The width, height and weight of the load differ according to the work equipment, so take this into account when determining the shipping route.
- When passing over bridges or structures on private land, check first that the structure is strong enough to support the weight of the machine. When traveling on public roads, check first with the relevant authorities and follow their instructions.
- For details of the shipping procedure, see "TRANSPORTATION (PAGE 3-88)" in the OPERATION section.

BATTERY

BATTERY HAZARD PREVENTION

Battery electrolyte contains sulphuric acid, and batteries generate flammable hydrogen gas, which may explode. Mistaken handling can lead to serious injury or fire. For this reason, always observe the following precautions.

- Do not use or charge the battery if the battery electrolyte level is below the LOWER LEVEL line. This may cause an explosion. Always check the battery electrolyte level periodically and add distilled water to bring the electrolyte level to the UPPER LEVEL line.
- When working with batteries, always wear safety glasses and rubber gloves.
- Never smoke or use any flame near the battery.

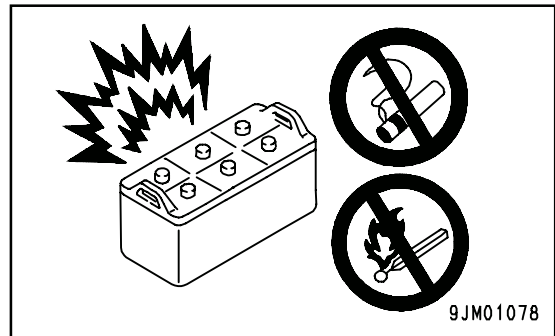

- If you spill acid on your clothes or skin, immediately flush the area with large amounts of water.
- If acid gets into your eyes, flush them immediately with large quantities of water and seek medical attention.

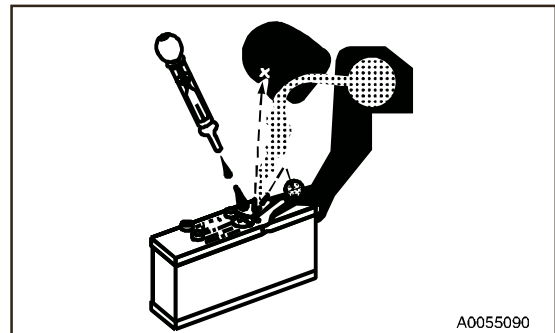

- Before working with batteries, turn the starting switch to the OFF position.

As there is a hazard that sparks will be generated, always do as follows.

- Do not let tools or other metal objects make any contact between the battery terminals. Do not leave tools or other metal objects lying around near the battery.
- Always disconnect the negative (-) terminal (ground side) first when removing the battery; when installing the battery, connect the positive (+) terminal first, and connect the ground last. Tighten the battery terminals securely.
- Flammable hydrogen gas is generated when the battery is charged, so remove the battery from the chassis, take it to a well-ventilated place, and remove the battery caps before charging it.
- Tighten the battery caps securely.
- Install the battery securely to the determined place.

STARTING WITH BOOSTER CABLE

If any mistake is made in the method of connecting the booster cables, it may cause the battery to explode, so always do as follows.

- When starting with a booster cable, carry out the starting operation with two workers (one worker sitting in the operator's seat and the other working with the battery).
- When starting from another machine, do not allow the two machines to touch.
- When connecting the booster cables, turn the starting switch OFF for both the normal machine and problem machine. There is a hazard that the machine will move when the power is connected.
- Be sure to connect the positive (+) cable first when installing the booster cables. Disconnect the ground or negative (-) cable (ground side) first when removing them.
- When removing the booster cables, be careful not to let the booster cable clips touch each other or to let the clips touch the machine.
- Always wear safety goggles and rubber gloves when starting the engine with booster cables.
- When connecting a normal machine to a problem machine with booster cables, always use a normal machine with the same battery voltage as the problem machine.
- For details of the starting procedure when using booster cables, see "STARTING ENGINE WITH BOOSTER CABLE (PAGE 3-105)" in the OPERATION section.

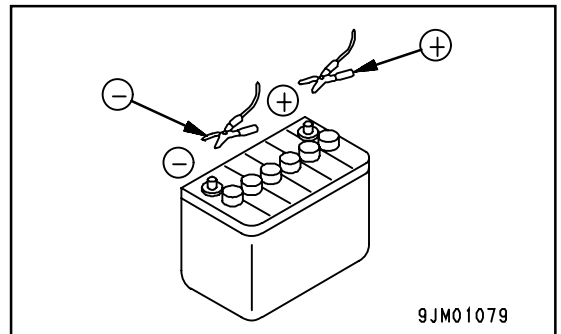
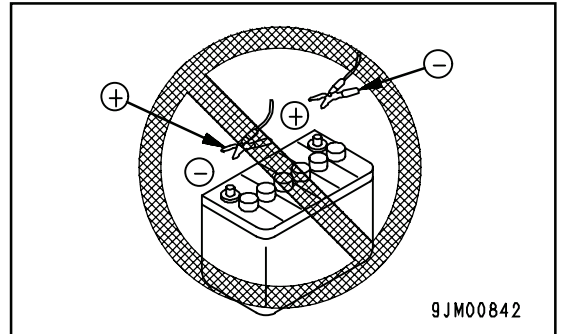

TOWING

WHEN TOWING

Serious injury or death could result if a disabled machine is towed incorrectly or if there is a mistake in the selection or inspection of the wire rope.

For towing method, see the section of "TOWING THE MACHINE (PAGE 3-102)".

- Always wear leather gloves when handling wire rope.
- Connect a wire rope to the part indicated with the arrow in the diagram at right.
- During the towing operation, never stand between the towing machine and the machine being towed.
- Never tow a machine on a slope.

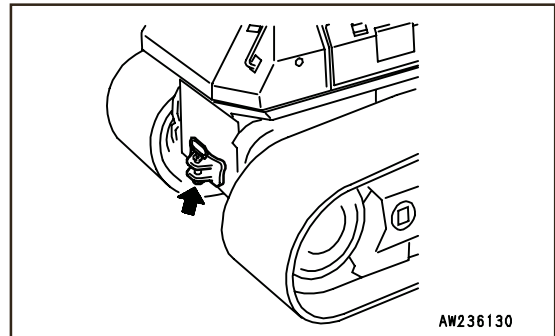

- Never use a wire rope which has cut strands (A), reduced diameter (B), or kinks (C). There is danger that the rope may break during the towing operation.

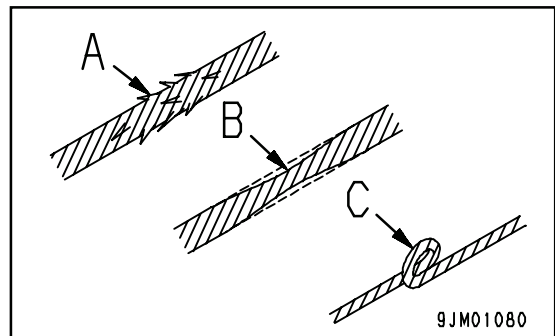

- If the engine stops or the oil pressure in the brake circuit lowers because of a trouble in the hydraulic system, the brake works and the machine cannot move. To move the machine in this case, the oil pressure in the brake circuit must be heightened to the specified level with a special device. Ask your Komatsu distributor.

PRECAUTIONS FOR MAINTENANCE

WARNING TAG

- Always attach the "DO NOT OPERATE" warning tag to the work equipment control lever in the operator's cab to alert others that you are performing service or maintenance on the machine. Attach additional warning tags around the machine if necessary.
 Warning tag Part No. 09963-03001
 Keep this warning tag in the tool box while it is not used. If there is not the tool box, keep the tag in the operation manual pocket.
- If others start the engine, or touch or operate the work equipment control lever while you are performing service or maintenance, you could suffer serious injury or property damage.

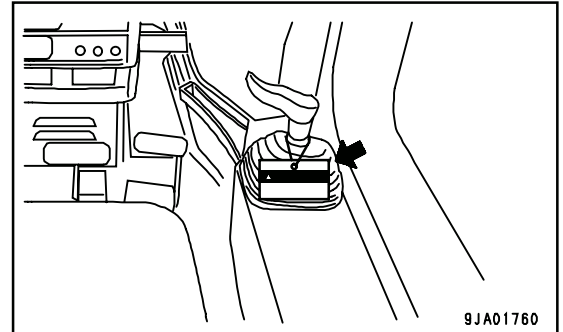

KEEP WORK PLACE CLEAN AND TIDY

Do not leave hammers or other tools lying around in the work place. Wipe up all grease, oil, or other substances that will cause you to slip. Always keep the work place clean and tidy to enable you to carry out operations safely. If the work place is not kept clean and tidy, there is the danger that you will trip, slip, or fall over and injure yourself.

APPOINT LEADER WHEN WORKING WITH OTHERS

When repairing the machine or when removing and installing the work equipment, appoint a leader and follow his instructions during the operation.

When working with others, misunderstandings between workers can lead to serious accidents.

STOP ENGINE BEFORE CARRYING OUT INSPECTION AND MAINTENANCE

- Stop the machine on firm, level ground.
- Select a place where there is no danger of falling rocks, landslides, or flooding.
- Lower the work equipment completely to the ground and stop the engine.

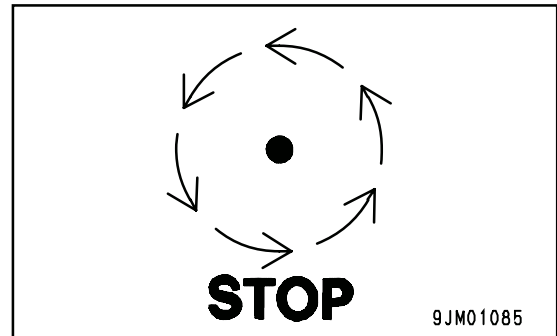

- Set safety lock lever (1) to the LOCK position.

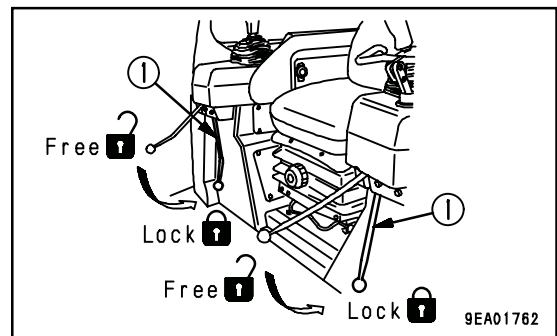

- Put blocks under the track to prevent the machine from moving.

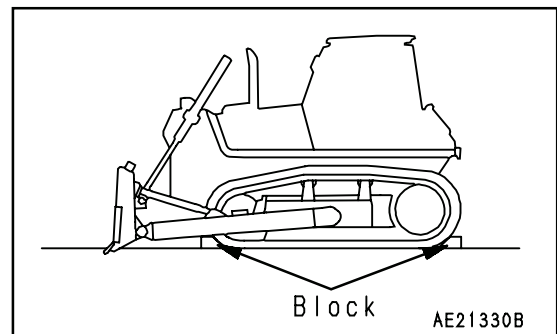

TWO WORKERS FOR MAINTENANCE WHEN ENGINE IS RUNNING

To prevent injury, do not carry out maintenance with the engine running. If maintenance must be carried out with the engine running, carry out the operation with at least two workers and do as follows.

- One worker must always sit in the operator's seat and be ready to stop the engine at any time. All workers must maintain contact with the other workers.
- set safety lock lever (1) to the LOCK position.
- When carrying out operations near the fan, fan belt, or other rotating parts, there is a hazard of being caught in the parts, so be extremely careful.
- Do not touch any control levers. If any control lever must be operated, always give a signal to the other workers to warn them to move to a safe place.
- Never drop or insert tools or other objects into the fan or fan belt. Parts may break or be sent flying.

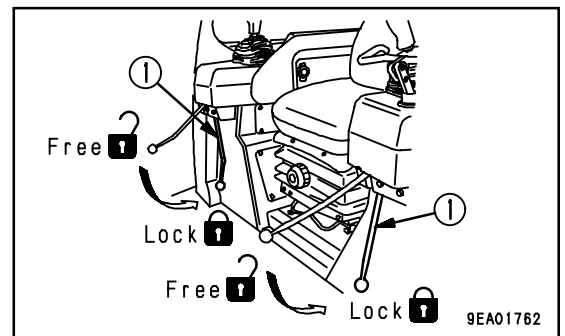
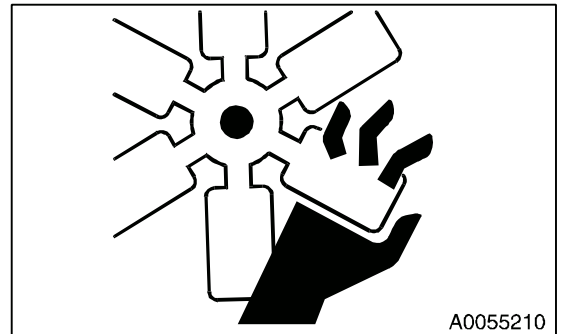

PROPER TOOLS

Use only tools suited to the task and be sure to use the tools correctly. Using damaged, low quality, faulty, makeshift tools or improper use of the tools could cause serious personal injury.

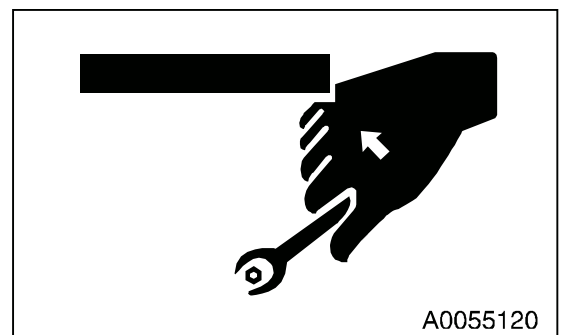

PERSONNAL

Only authorized personnel can service and repair the machine. Do not allow unauthorized personnel into the area. If necessary, employ an observer.

ATTACHMENTS

- Appoint a leader before starting removal or installation operations for attachments.
- Place attachments that have been removed from the machine in a stable condition so that they do not fall. And take steps to prevent unauthorized persons from entering the storage area.



A0055130

PRECAUTIONS FOR WORK UNDER MACHINE AND WORK EQUIPMENT

- If it is necessary to go under the work equipment or the machine to carry out service and maintenance, support the work equipment and machine securely with blocks and stands strong enough to support the weight of the work equipment and machine.
- It is extremely dangerous to work under the machine if the track shoes are off the ground and the machine is supported only by the work equipment. If the control levers are touched by mistake, or there is a hazard to the hydraulic line, the work equipment or the machine may suddenly descend. This is extremely dangerous. Never work under the machine if the machine is not properly supported by blocks or stands.



A0055140

NOISE

If the noise from the machine is too loud, it may cause temporary or permanent hearing problems.

When carrying out maintenance of the engine and you are exposed to noise for long periods of time, wear ear covers or ear plugs while working.

PRECAUTIONS WHEN USING HAMMER

When using a hammer, pins may fly out or metal particles may be scattered. This may lead to serious injury. Always do as follows.

- If hard metal parts such as pins, or bearings are hit with a hammer, there is a hazard that pieces might be scattered and cause injury. Always wear safety goggles and gloves.
- When hitting pins, there is a hazard that broken pieces might be sent flying and injure people in the surrounding area. Always check that there is no one in the surrounding area.
- If pins are hit with strong force, there is a hazard that the pin may fly out and injure people in the surrounding area.

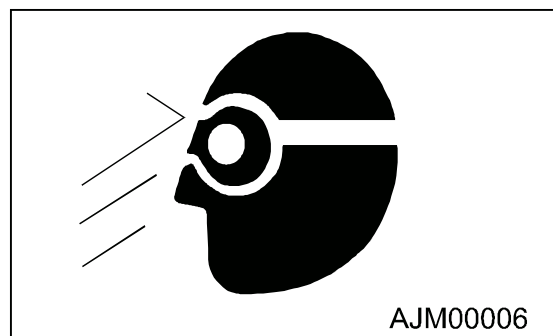

AJM00006

REPAIR WELDING

Welding operations must always be carried out by a qualified welder and in a place equipped with a proper equipment. There is a hazard of fire or electrocution when carrying out welding, so never allow any unqualified personnel to carry out welding.

REMOVING BATTERY TERMINAL

When repairing the electrical system or when carrying out electrical welding, remove the negative (-) terminal of the battery to prevent the flow of current.

PRECAUTIONS WHEN USING HIGH-PRESSURE GREASE TO ADJUST TRACK TENSION

- Grease is pumped into the track tension adjustment system under high pressure. If the specified procedure for maintenance is not followed when making adjustment, grease drain plug (1) may fly out and cause serious injury or property damage.
- When loosening grease drain plug (1) to loosen the track tension, never loosen it more than one turn. Loosen the grease drain plug slowly.
- Never put your face, hands, feet, or any other part of your body close to grease drain plug (1).

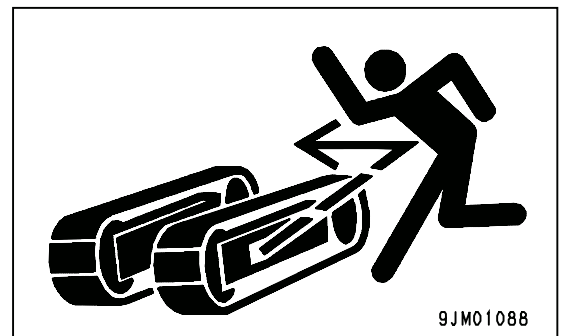
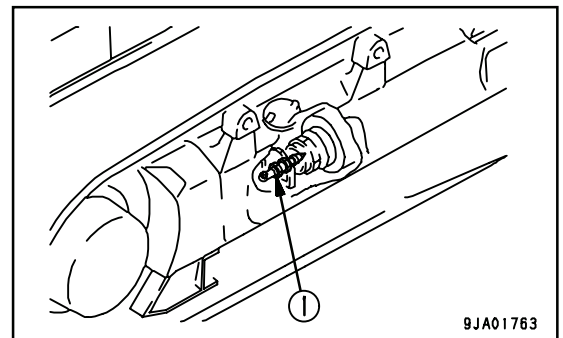

DO NOT DISASSEMBLE RECOIL SPRING

The recoil spring assembly is used to reduce the impact on the idler. It contains a spring under high pressure, so if it is disassembled by mistake, the spring will fly out and cause serious injury or even death. Never disassemble the recoil spring.

PRECAUTION WITH HIGH-PRESSURE OIL

The hydraulic system is always under internal pressure. When inspecting or replacing piping or hoses, always check that the pressure in the hydraulic circuit has been released. If the circuit is still under pressure, it will lead to serious injury or property damage, so always do as follows.

- For the releasing procedure of the internal pressure, see "PROCEDURE FOR RELEASING INTERNAL PRESSURE OF HYDRAULIC SYSTEM (PAGE 4-38)". Do not inspect or replace any part while the internal pressure is applied.
- If there is any leakage from the piping or hoses, the surrounding area will be wet, so check for cracks in the piping and hoses and for swelling in the hoses.
When carry out inspection, wear safety glasses and leather gloves.
- There is a hazard that high-pressure oil leaking from small holes may penetrate your skin or cause blindness if it contacts your eyes directly. If you are hit by a jet of high-pressure oil and suffer injury to your skin or eyes, wash the place with clean water, and consult a doctor immediately for medical attention.



HANDLING HIGH-PRESSURE HOSES

- If oil or fuel leaks from high-pressure hoses, it may cause fire or defective operation, which may lead to serious injury or property damage. If any loose bolts are found, stop work and tighten to the specified torque. If any damaged hoses are found, stop operations immediately and contact your Komatsu distributor.

Replace the hose if any of the following problems are found.

- Damaged or leaking hydraulic fitting.
- Frayed or cut covering or exposed reinforcement layer of wire.
- Covering swollen in places.
- Twisted or crushed movable portion.
- Foreign material embedded in covering.

WASTE MATERIAL

To prevent pollution, pay careful attention to the method of disposing of waste materials.

- Always put oil drained from your machine in containers. Never drain oil directly onto the ground or dump into the sewage system, rivers, the sea, or lakes.
- Obey appropriate laws and regulations when disposing of harmful objects such as oil, fuel, coolant, solvent, filters, and batteries.

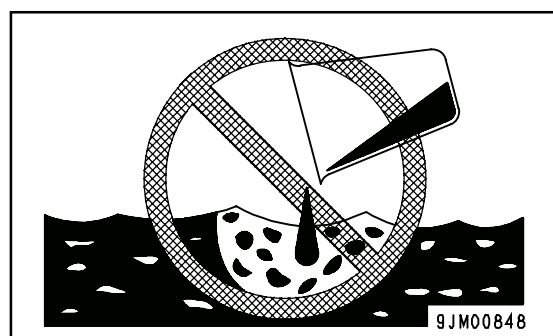

MAINTENANCE FOR AIR CONDITIONER

If air conditioner refrigerant gets into your eyes, it may cause blindness; if it touches your skin, it may cause frost-bite. Never touch refrigerant.

COMPRESSED AIR

- When carrying out cleaning with compressed air, there is a hazard of serious injury or property damage caused by flying particles.
- When using compressed air to clean elements or the radiator, always wear safety goggles, dust mask, gloves, and other protective equipment.

PERIODIC REPLACEMENT OF SAFETY CRITICAL PARTS

- In order for the machine to be operated safely for a long time, it is necessary to add oil and to carry out service and maintenance at periodic intervals. In order to further increase safety, components with a strong relationship to safety, such as hoses and seat belts, must be replaced at periodic intervals.

Replacement of safety critical parts: See "PERIODIC REPLACEMENT OF SAFETY CRITICAL PARTS (PAGE 4-14)".

- The material of these components naturally changes over time, and repeated use causes deterioration, wear, and fatigue. As a result, there is a hazard that these components may fail and cause serious injury or property damage. It is difficult to judge the remaining life of these components from external inspection or the feeling when operating, so always replace them at the specified interval.
- Replace or repair safety critical parts if any defect is found, even when they have not reached the time specified interval.

OPERATION

 **WARNING**

Please read and make sure that you understand the safety volume before reading this section.

GENERAL VIEW

GENERAL VIEW OF MACHINE

Machine equipped with cab

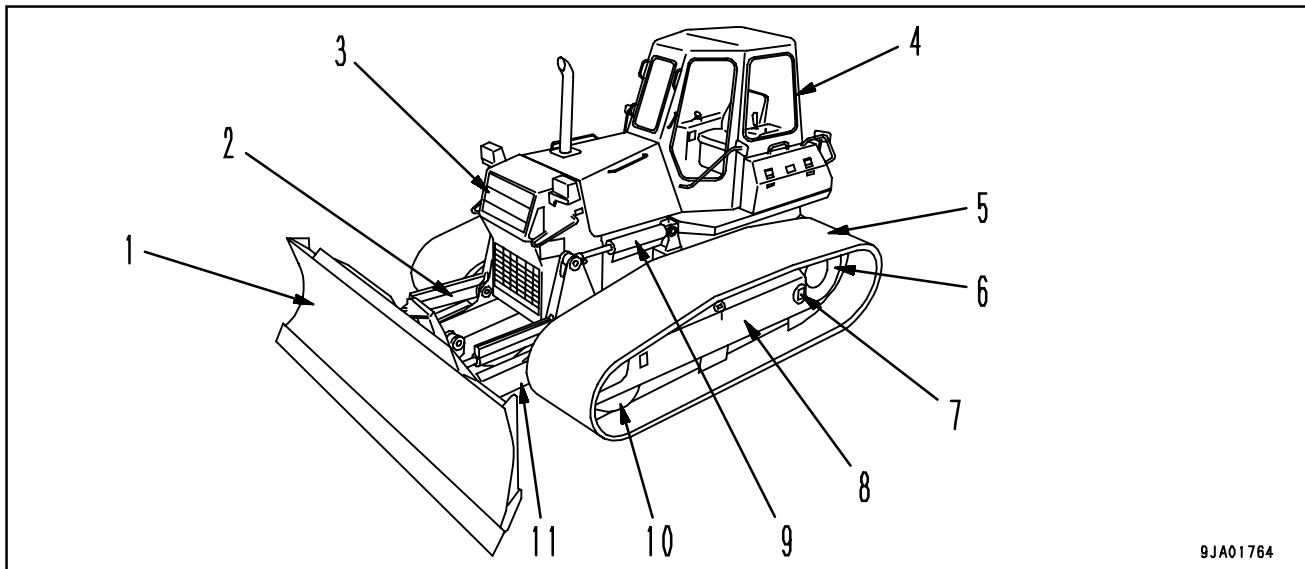

9JA01764

Machine equipped with canopy

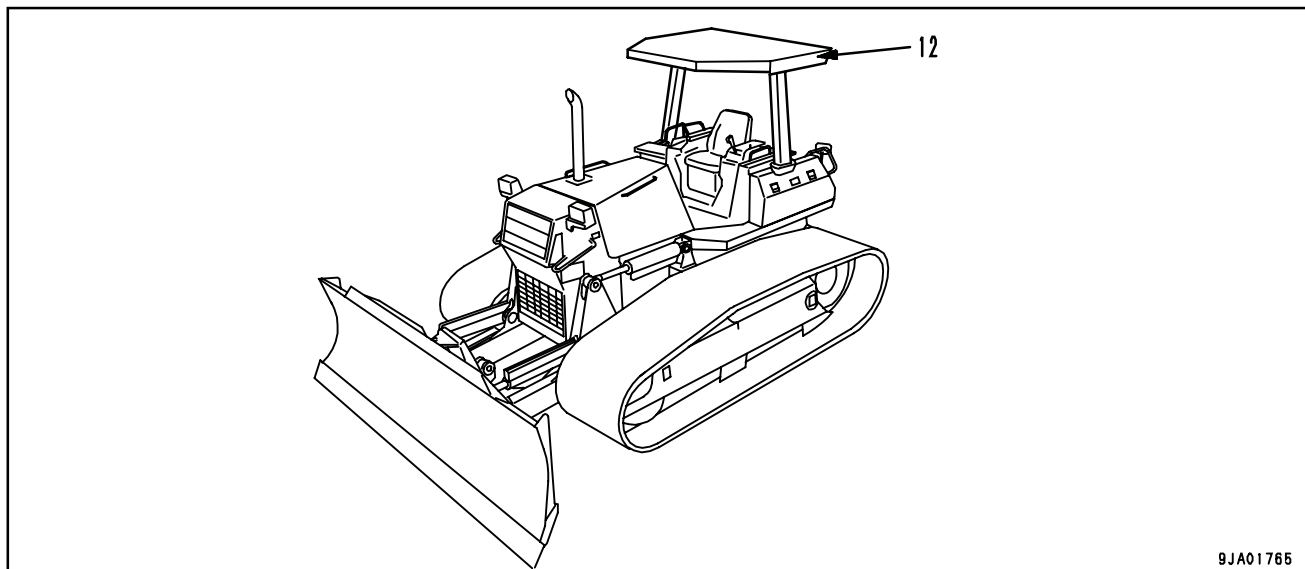

9JA01765

- | | |
|--------------------|-------------------|
| (1) Blade | (7) Pivot shaft |
| (2) Angle cylinder | (8) Track frame |
| (3) Radiator mask | (9) Lift cylinder |
| (4) Cab | (10) Idler |
| (5) Track shoe | (11) Frame |
| (6) Sprocket | (12) Canopy |

GENERAL VIEW OF CONTROLS AND GAUGES

Machine equipped with cab

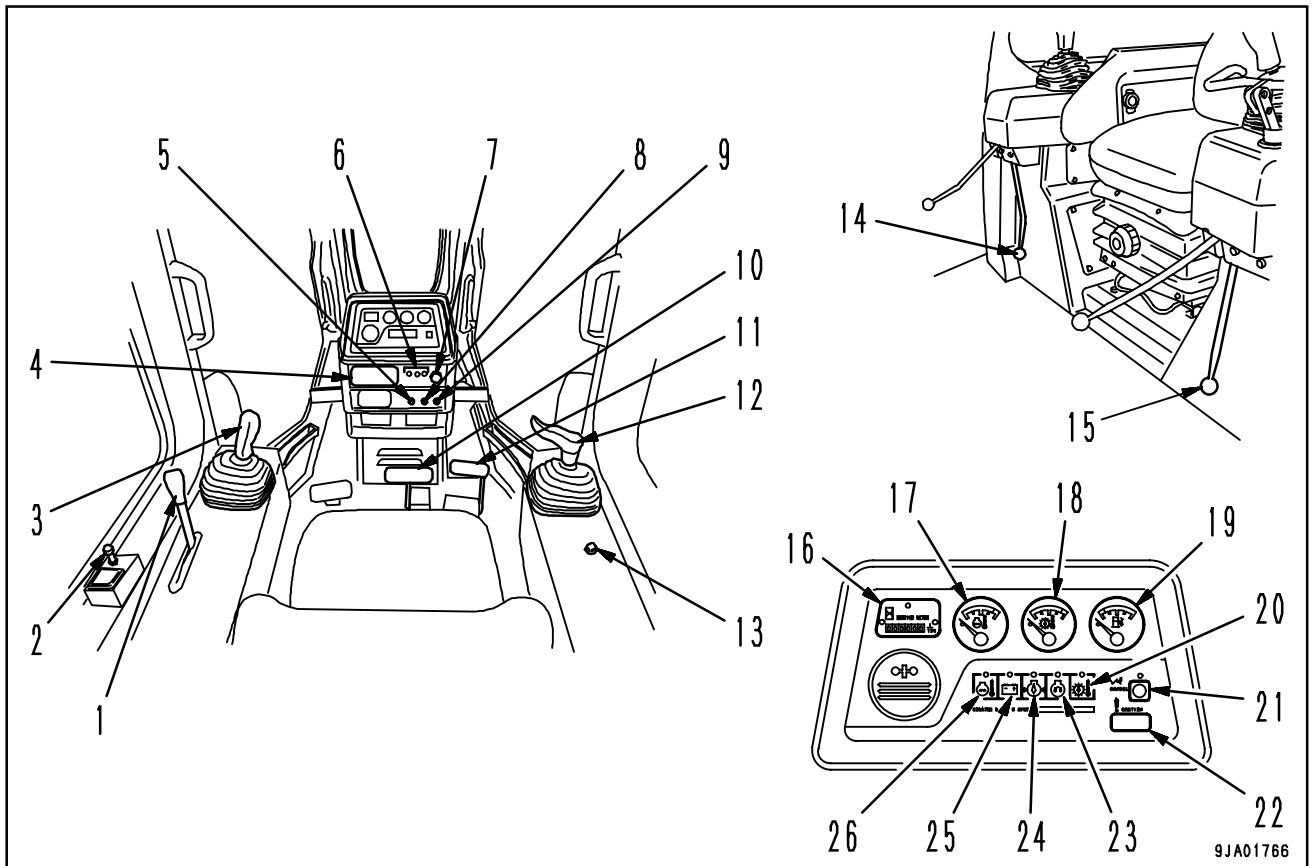

- | | |
|--|--|
| (1) Fuel control lever | (14) Safety lock lever (for blade control lever) |
| (2) Cigarette lighter | (15) Brake lock lever |
| (3) Steering, directional and gear shift lever | (16) Service meter |
| (4) Air conditioner panel or heater panel | (17) Engine water temperature gauge |
| (5) Head lamp switch | (18) Transmission oil temperature gauge |
| (6) Speed range display lamp | (19) Fuel gauge |
| (7) Starting switch | (20) Transmission oil temperature caution lamp |
| (8) Rear lamp switch | (21) Monitor caution cancel switch |
| (9) Glow switch | (22) Monitor caution lamp |
| (10) Brake pedal | (23) Glow signal lamp |
| (11) Decelerator pedal | (24) Engine oil pressure caution lamp |
| (12) Blade control lever | (25) Charge lamp |
| (13) Horn switch | (26) Engine water temperature caution lamp |

Machine equipped with canopy

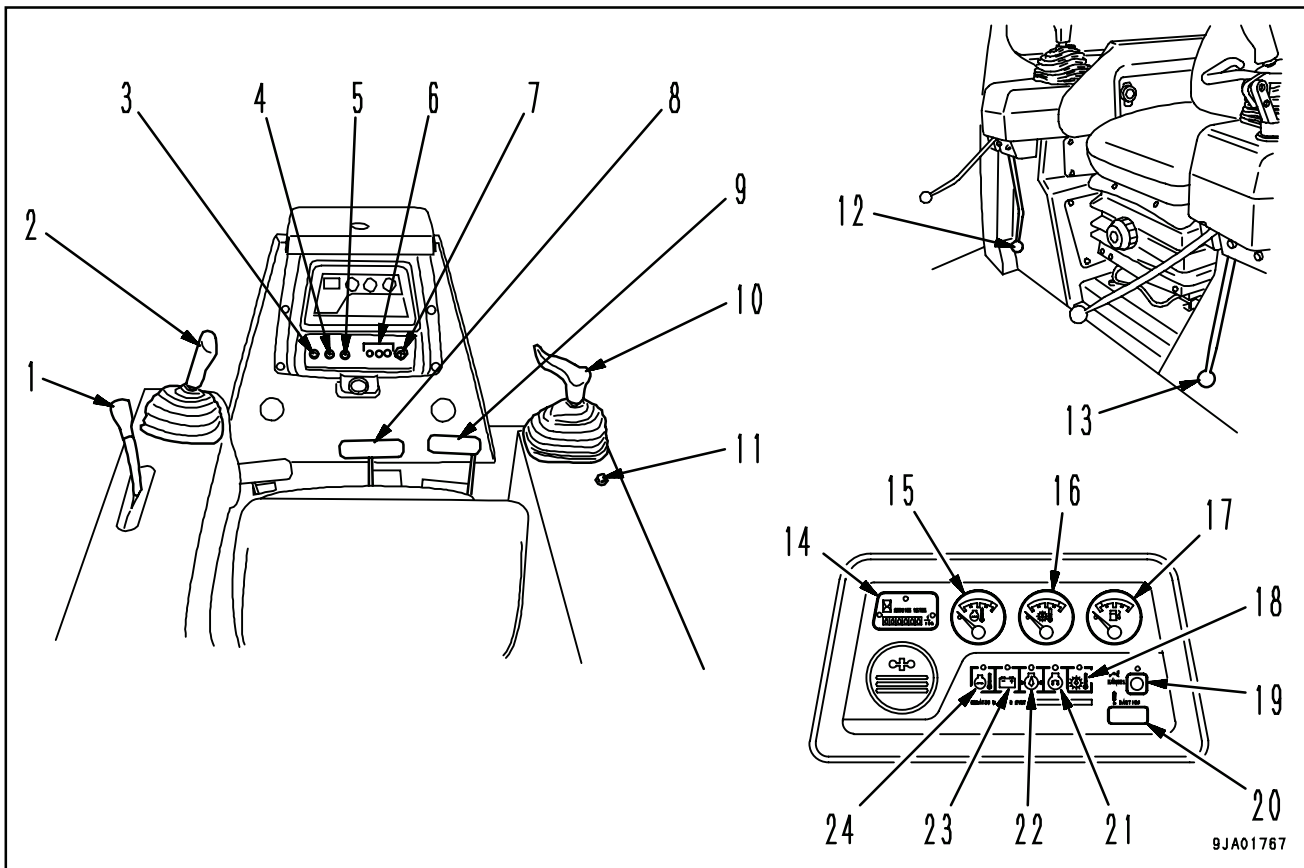

- | | |
|--|--|
| (1) Fuel control lever | (13) Brake lock lever |
| (2) Steering, directional and gear shift lever | (14) Service meter |
| (3) Head lamp switch | (15) Engine water temperature gauge |
| (4) Rear lamp switch | (16) Transmission oil temperature gauge |
| (5) Glow switch | (17) Fuel gauge |
| (6) Speed range display lamp | (18) Transmission oil temperature caution lamp |
| (7) Starting switch | (19) Monitor caution cancel switch |
| (8) Brake pedal | (20) Monitor caution lamp |
| (9) Decelerator pedal | (21) Glow signal lamp |
| (10) Blade control lever | (22) Engine oil pressure caution lamp |
| (11) Horn switch | (23) Charge lamp |
| (12) Safety lock lever (for blade control lever) | (24) Engine water temperature caution lamp |

EXPLANATION OF COMPONENTS

The following is an explanation of the devices needed for operating the machine.

To carry out suitable operations correctly and safely, it is important to understand fully the methods of operating the equipment and the meanings of the displays.

MONITOR PANEL

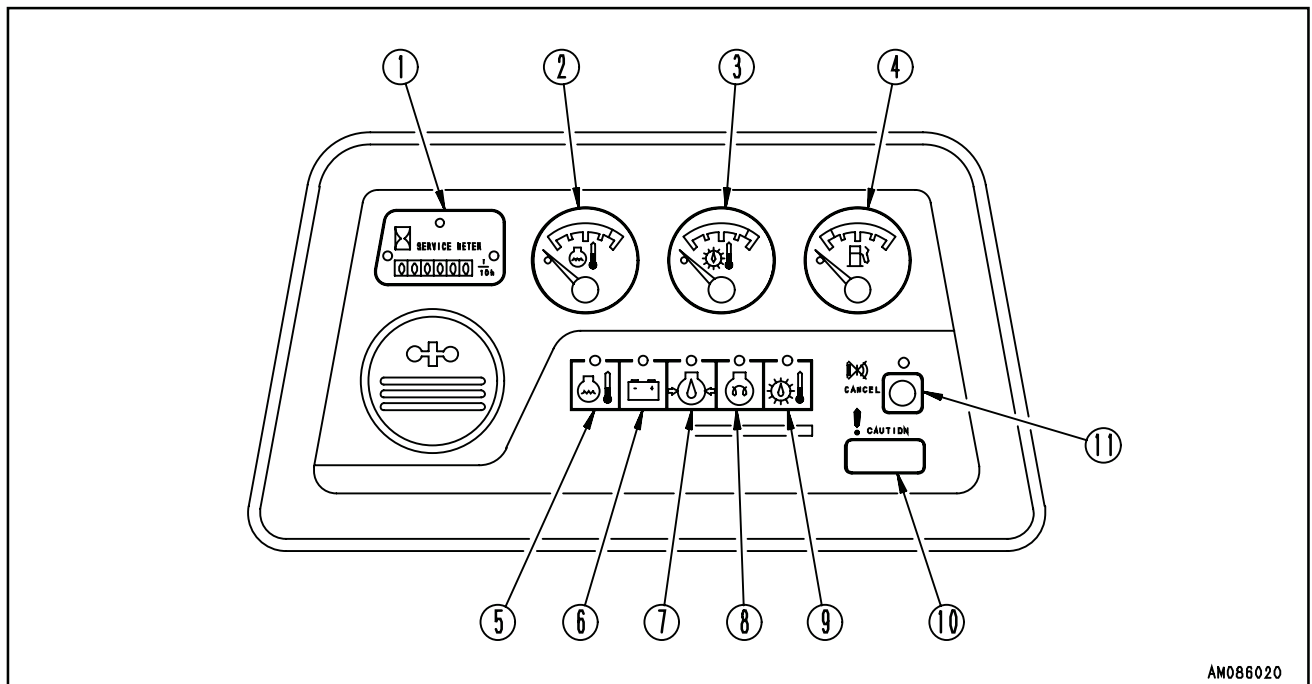

- | | |
|---|---|
| (1) Service meter | (7) Engine oil pressure caution lamp |
| (2) Engine water temperature gauge | (8) Glow signal lamp |
| (3) Transmission oil temperature gauge | (9) Transmission oil temperature caution lamp |
| (4) Fuel gauge | (10) Monitor caution lamp |
| (5) Engine water temperature caution lamp | (11) Monitor caution cancel switch |
| (6) Charge lamp | |

SERVICE METER

This meter(1) shows the total operation hours of the machine. Set the periodic maintenance intervals using this display. The service meter advances while the engine is running, even if the machine is not traveling.

While the engine is running, the pilot lamp (A) at the top of the meters keeps flashing to indicate that the meter is advancing. Meter (B) will advance by 1 for each hour of operation regardless of the engine speed.

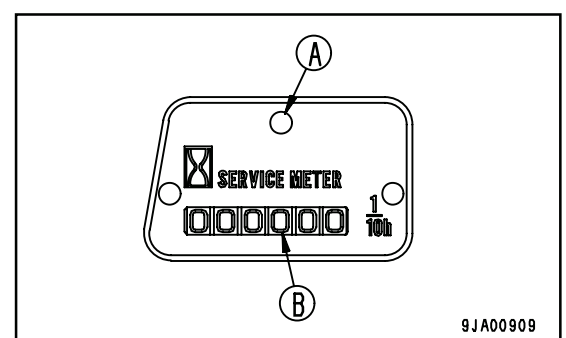

ENGINE WATER TEMPERATURE GAUGE

This gauge(2) indicates the cooling water temperature.

When the indicator is in the white range during operation, the water temperature is normal.

If the indicator moves from the white range into the red range during operation, stop the machine immediately, run the engine under no load at a midrange speed, and wait for the indicator to go down to the white range. After starting the engine, warm up it until the indicator moves into the white range.

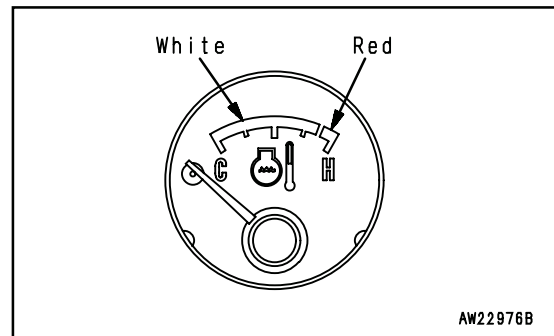

TRANSMISSION OIL TEMPERATURE GAUGE

This meter(3) indicates the temperature of the transmission lubricating oil.

When the indicator is in the white range during operation, the oil temperature is normal.

If the indicator moves from the white range into the red range during operation, stop the machine, run the engine under no load at a midrange speed, and wait for the indicator to go down to the white range.

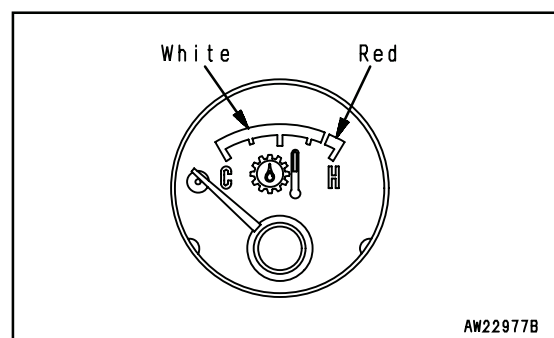

FUEL GAUGE

When the starting switch is turned ON, this meter(4) displays the amount of fuel remaining in the fuel tank.

F indicates a full tank.

When the indicator points to E, it indicates that there is less than 43 liters (11.35US gal) remaining, so add fuel.

Always fill the tank after finishing operations.

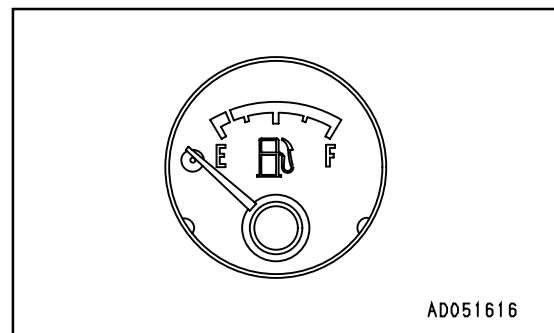

ENGINE WATER TEMPERATURE CAUTION LAMP

This lamp(5) warns of a rise in the temperature of the engine cooling water.

If the lamp lights up, stop the machine, run the engine under no load at a midrange speed, and wait for the indicator of the engine water temperature gauge to go down to the white range.

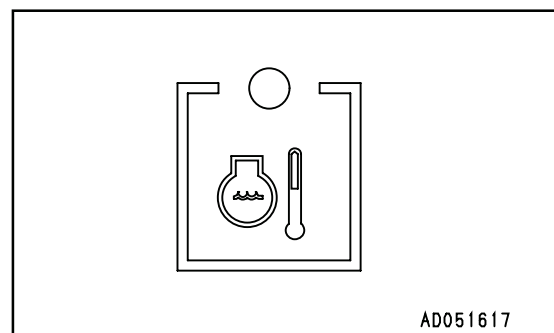

CHARGE LAMP

This lamp(6) indicates malfunction of the alternator.

When the starting switch is turned ON, it will light up, but it should go out when the engine speed rises.

If the lamp lights up during operation, stop the engine and check the V-belt tension. If any abnormality is found, see "OTHER TROUBLE (PAGE 3-107)".

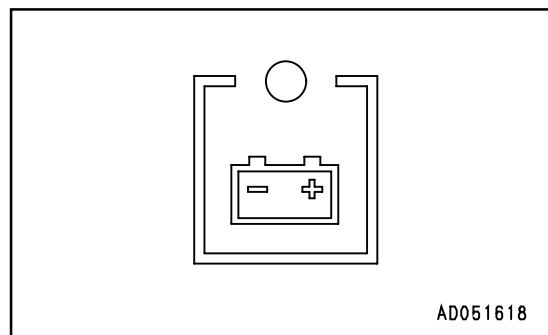

ENGINE OIL PRESSURE CAUTION LAMP

This lamp(7) warns that the engine lubricating oil pressure has dropped. When the starting switch is turned ON, it will light up. When the lamp goes off after the engine is started, the oil pressure is normal.

When the lamp lights up during operation, the oil pressure is lower. Immediately stop the engine and look for the cause. For details, see "OTHER TROUBLE (PAGE 3-107)".

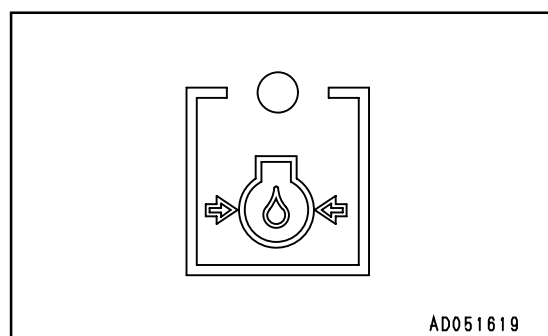

GLOW SIGNAL LAMP

This lamp(8) indicates the electrical intake air heater is re-heated. While preheating is being carried out with the glow switch, the lamp lights up.

In the case of automatic preheating, the lamp goes out when the preheating is completed.

In the case of manual preheating, the lamp goes out when the glow switch is released.

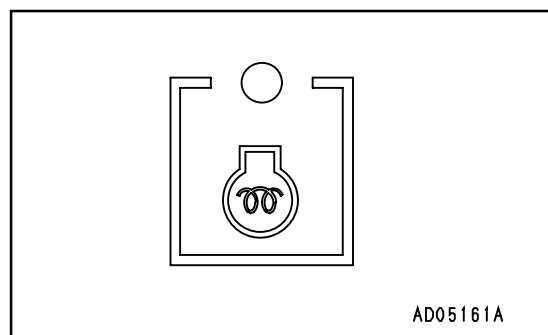

TRANSMISSION OIL TEMPERATURE CAUTION LAMP

This lamp(9) warns the operator that the oil temperature at the transmission outlet port has risen.

If the lamp lights up, stop the machine, run the engine under no load at a midrange speed, and wait for the transmission oil temperature gauge to go down to the white range.

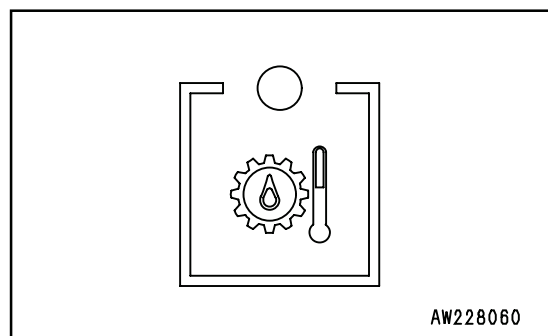

MONITOR CAUTION LAMP

This lamp(10) lights up when any of the following caution lamps lights up.

In addition, the alarm buzzer sounds at the same time.

- Engine water temperature caution lamp
- Charge lamp
- Engine oil pressure caution lamp
- Transmission oil temperature caution lamp

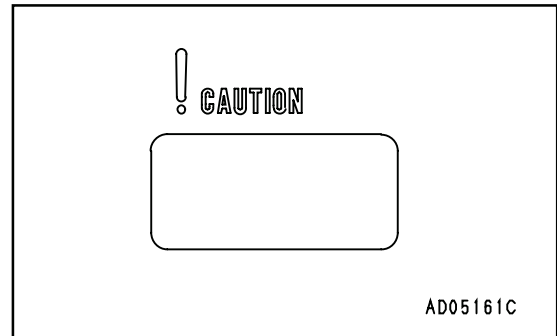

MONITOR CAUTION CANCEL SWITCH

This switch(11) is used to cancel monitor caution lamp. Press the switch to turn the monitor caution lamp out and to stop the alarm buzzer.

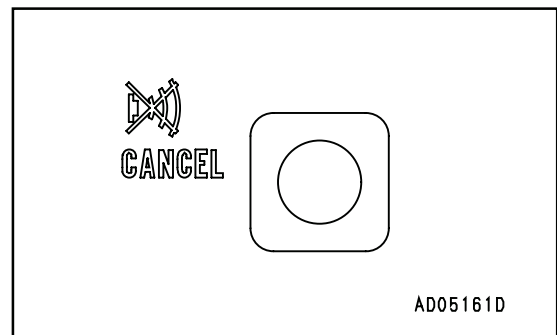

SWITCHES

Machine equipped with cab

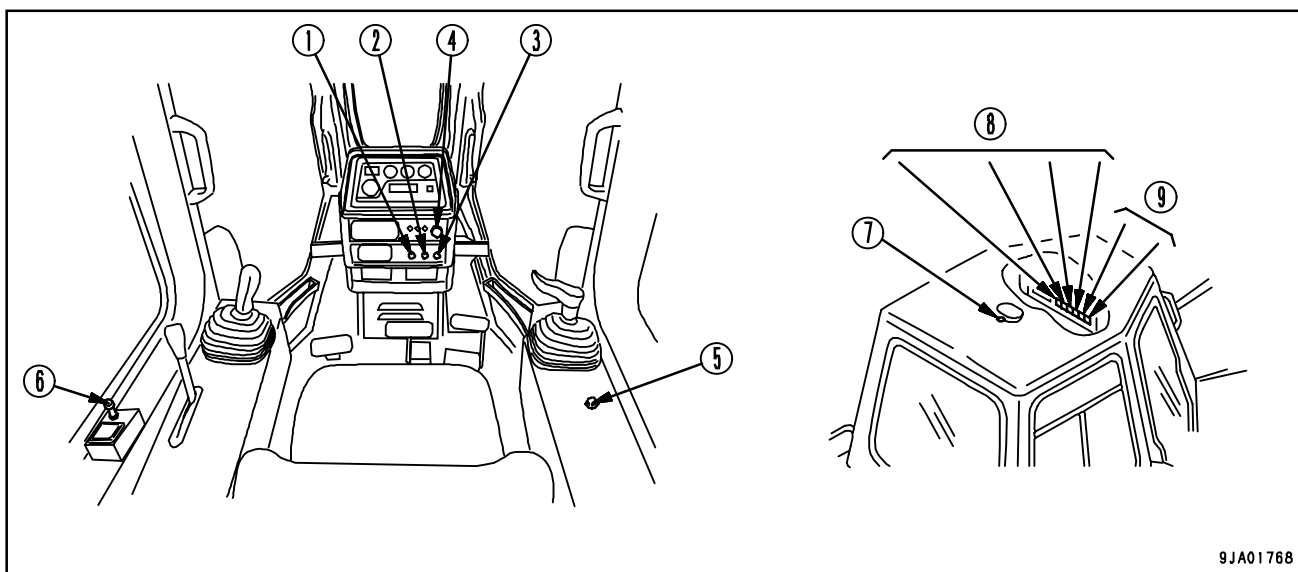

9JA01768

Machine equipped with canopy

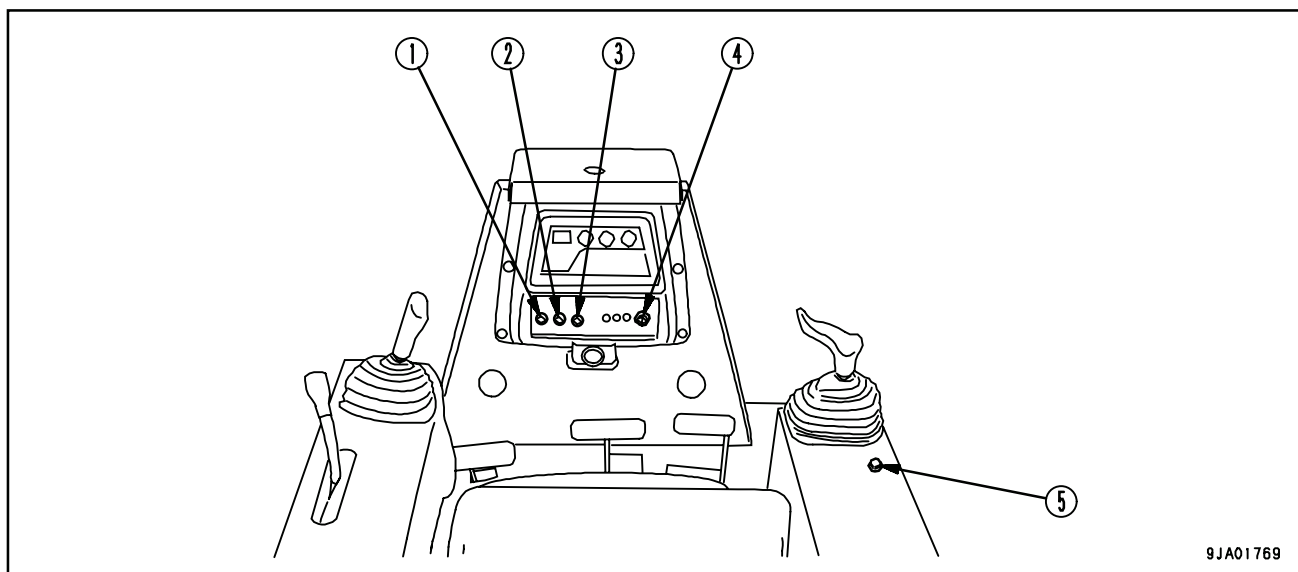

9JA01769

- (1) Head lamp switch
- (2) Rear lamp switch
- (3) Glow switch
- (4) Starting switch
- (5) Horn switch

- (6) Cigarette lighter (machine equipped with cab)
- (7) Room lamp (machine equipped with cab)
- (8) Wiper switch (machine equipped with cab)
- (9) Additional working lamp switch
(machine equipped with cab) (if equipped)

HEAD LAMP SWITCH

This switch(1) lights up the head lamps.

OFF position: Lamps are out

ON position: Lamps light up

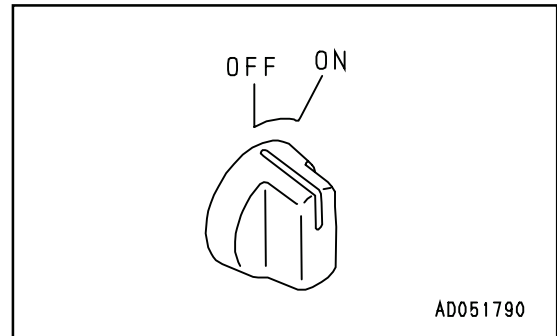

REAR LAMP SWITCH

This switch(2) lights up the rear lamps.

OFF position: Lamps are out

ON position: Lamps light up

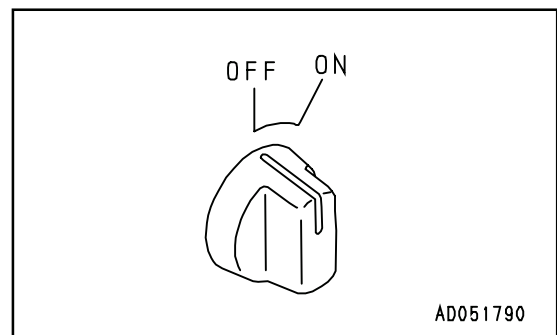

GLOW SWITCH

This switch(3) actuates the electrical heater to warm up the engine intake air.

OFF position: The preheating is not actuated.

AUTO position: AUTO preheating is actuated. The length of the preheating time varies according to the ambient temperature when the ambient temperature is below approx. -5°C .

I position: This is used when AUTO preheating is not enough to start the engine in cold weather simply with the glows witch at the AUTO position. When the switch is released, it will return to the AUTO position.

II position: This is used when carrying out preheating manually without using AUTO preheating. When the switch is released, it will return to the OFF position.

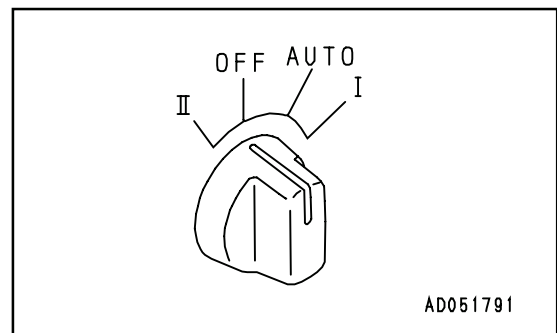

STARTING SWITCH

This switch(4) is used to start the engine.

OFF position:

At this position, the starting switch key can be inserted and removed. When the switch is turned to this position, all the electric circuits are turned off and the engine stops.

ON position:

In this position, electric current flows in the charging and lamp circuits.

Keep the starting switch key at the ON position while the engine is running.

START position:

This is the position to start the engine. Hold the key at this position while cranking. Release the key immediately after the engine has been started. The key will return to ON position when released.

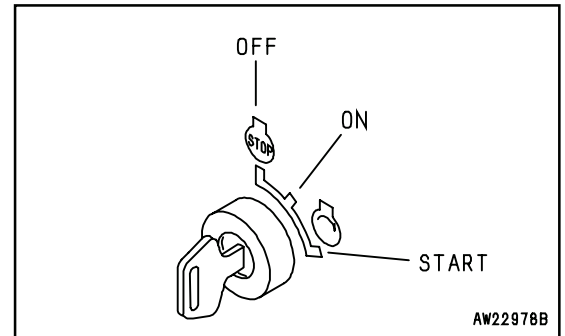

HORN SWITCH

The horn sounds when the button(5) at the rear of the blade control lever at the right side of the operator's seat is pressed.

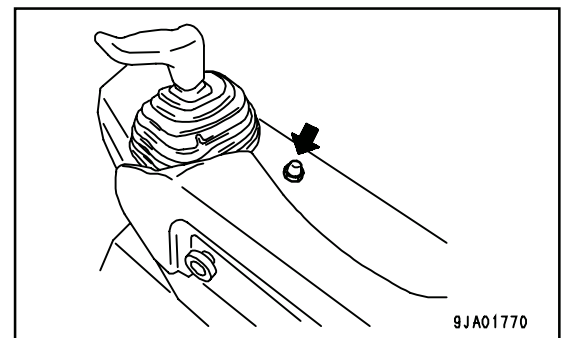

CIGARETTE LIGHTER

(Machine equipped with cab)

This lighter(6) is used to light cigarettes.

When the cigarette lighter is pushed in, it will return to its original position after a few seconds, so take it out to light your cigarette. If the cigarette lighter is removed, the socket can be used as a power source.

NOTICE

This cigarette lighter is 24V. Do not use it as the power source for 12 V equipment. If it is used so, the equipment may be broken.

The capacity of the cigarette lighter is 120W (24V x 5A).

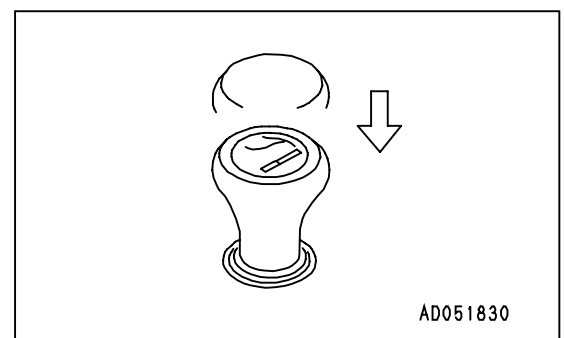

ROOM LAMP SWITCH

(Machine equipped with cab)

This lamp is used to turn on and off room lamp(7).

ON position: Lamp lights up

OFF position: Lamp is out

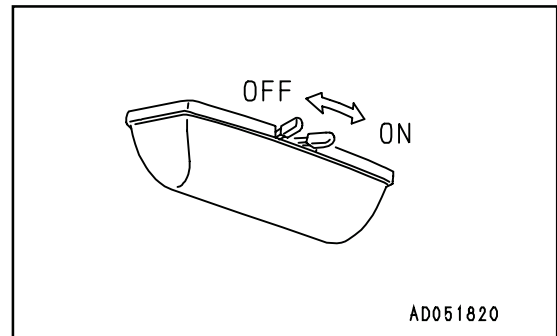

WIPER SWITCH

(Machine equipped with cab)

This switch(8) activates the wipers.

The wiper switches are as follows.

- (A) Left door
- (B) Front window
- (C) Right door
- (D) Rear window

This is also used as the window washer switch.

The switch is operated as follows.

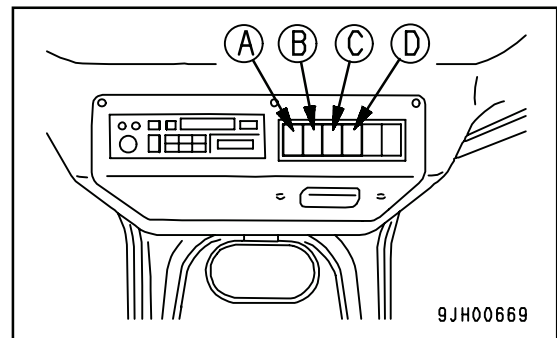

- Window washer only

Keep the switch pressed to the OFF position to spray out water.

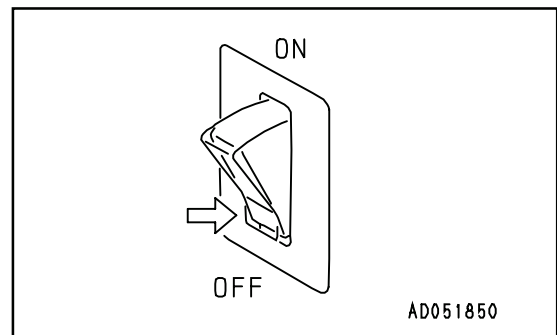

- Wiper only

If this is switched on, the wiper will start.

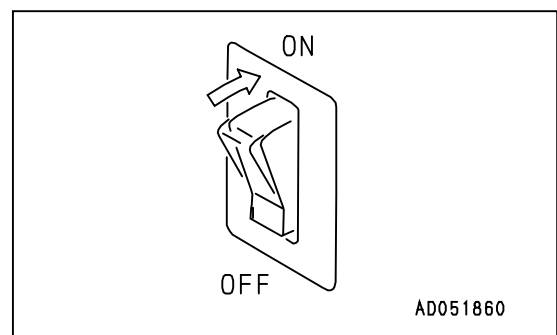

OPERATION**EXPLANATION OF COMPONENTS**

- Wiper and window washer

If this is kept pressed to the ON position while the wiper is working, water will be sprayed out.

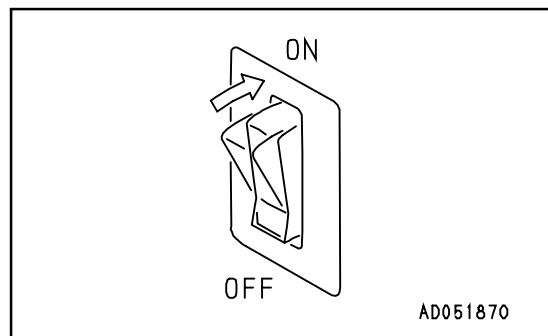
**ADDITIONAL WORK LAMP SWITCH**

(Machine equipped with cab) (If equipped)

This switch(9) is used to turn on the additional working lamp.

- (A)Head lamp switch
- (B)Rear lamp switch

Push in the direction of the arrow to turn on the lamps.

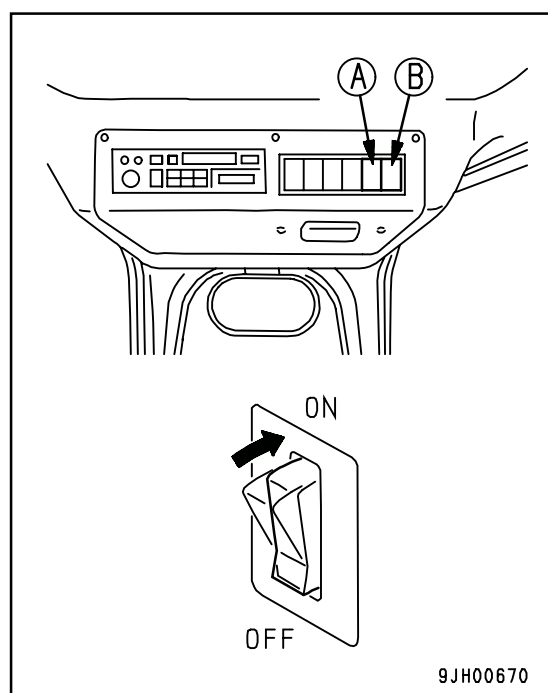

LAMP

Machine equipped with cab. Following illustration shows machine equipped with air conditioner.

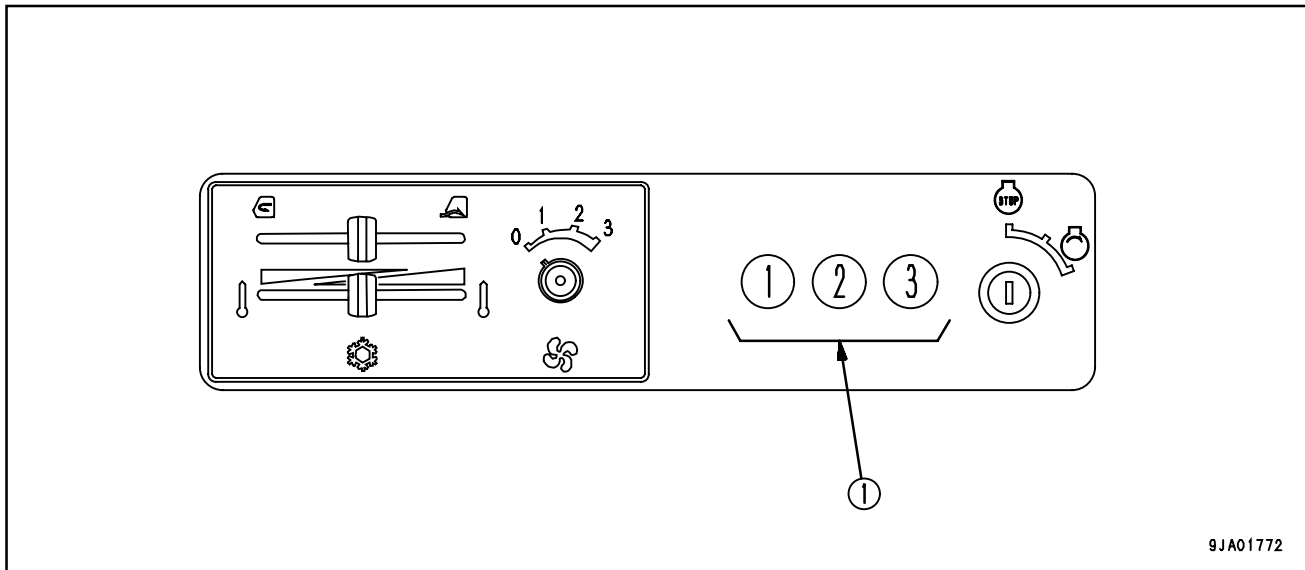

Machine equipped with canopy

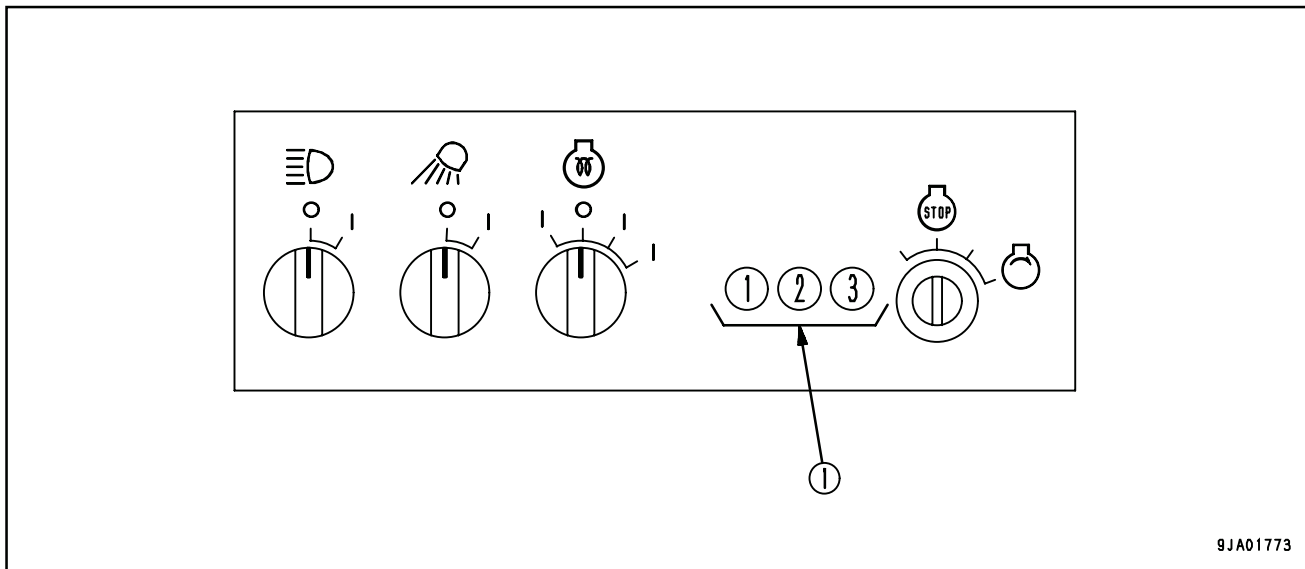

(1)Speed range display lamp

SPEED RANGE DISPLAY LAMP

This lamp(1) indicates the currently selected gear speed range.

- When lamp 1 lights up: 1st
- When lamp 2 lights up: 2nd
- When lamp 3 lights up: 3rd

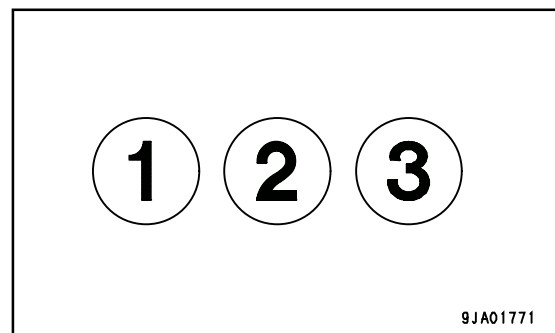

CONTROL LEVERS AND PEDALS

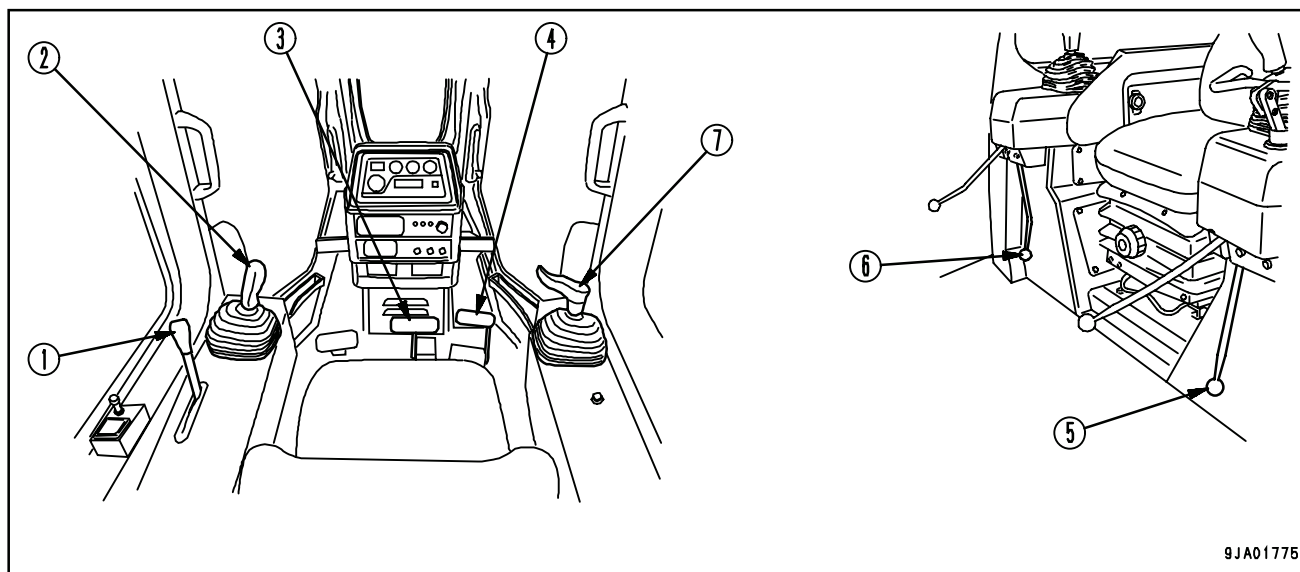

- | | |
|--|---|
| (1) Fuel control lever | (5) Brake lock lever |
| (2) Steering, directional and gear shift lever | (6) Safety lock lever (for blade control lever) |
| (3) Brake pedal | (7) Blade control lever |
| (4) Decelerator pedal | |

FUEL CONTROL LEVER

This lever (1) is used to control the engine speed and output.

- (a) Low idling position: Push the lever forward fully.
 (b) High idling position: Pull the lever fully

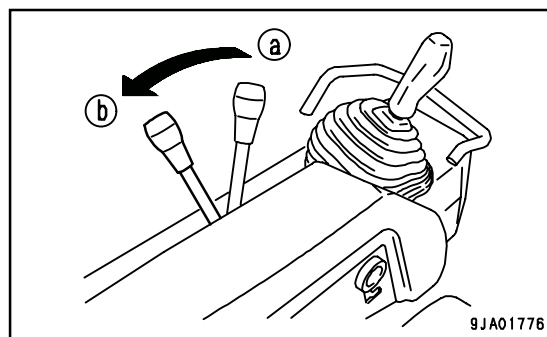

STEERING, DIRECTIONAL AND GEAR SHIFT LEVER

This lever(2) is used to select the direction of travel, to carry out steering, and to carry out counterrotation turns.

- Forward-reverse shifting

Position (a): FORWARD

Position (b): REVERSE

Position N: NEUTRAL

- Steering

Position (c): LEFT TURN

Position (d): RIGHT TURN

Position (e): LEFT COUNTER-ROTATION

Position (f): RIGHT COUNTER-ROTATION

Move the lever to the FRONT to travel FORWARD

Move the lever to the REAR to travel in REVERSE

If the lever is set in the forward or reverse travel position and turned to the right or left, the machine turns to the right or left smoothly according to the stroke of the lever.

If the lever is fully turned to the right or left, the turning radius is shortened.

If the lever is set in the N(Neutral) and turned to the right or left, the machine turns to the right or left by counter-rotation.

REMARK

- If the lever is released when steering the machine, the lever will return to the (a) position or the (b) position and the machine will be returned to straight movement.
- If you support the lever guide with your hand when steering, the turning operation will be easier.

- Gear shifting

Rotate the joystick 30° to carry out gear shifting operation.

Position (a): 1st

Position (b): 2nd

Position (c): 3rd

For the maximum travel speed in each gear speed, see "SPECIFICATIONS (PAGE 5-2)".

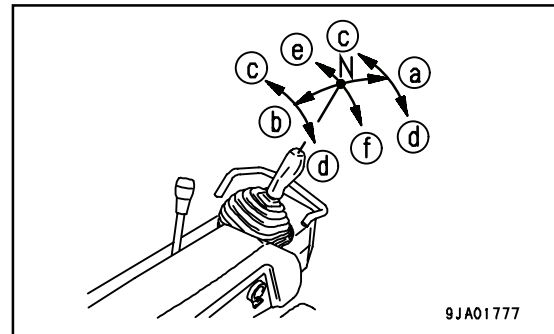

9JA01777

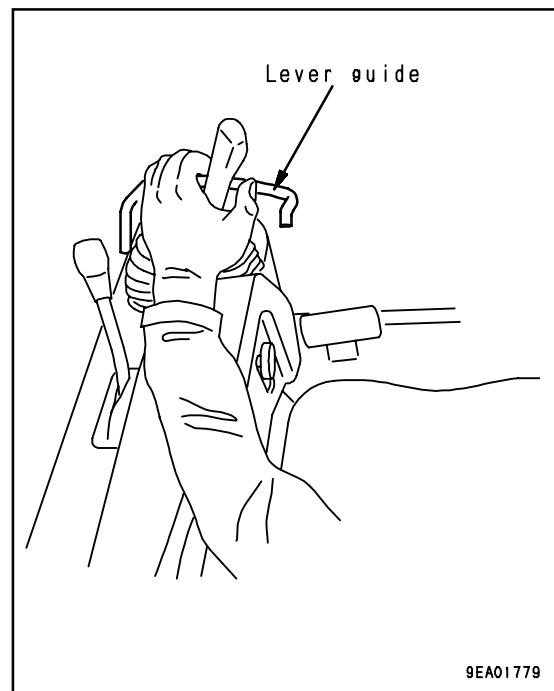

9EA01779

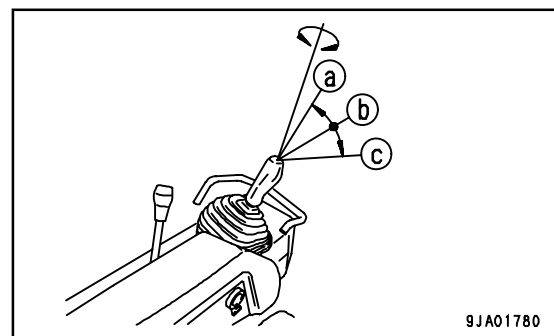

9JA01780

OPERATION

EXPLANATION OF COMPONENTS

As the gear is shifted, one of the gear speed lamps on the front panel lights up.

- 1st: Lamp 1 lights up.
- 2nd: Lamp 2 lights up.
- 3rd: Lamp 3 lights up.

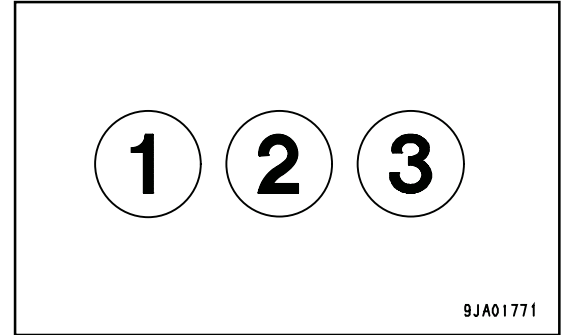

- Counterrotation turn

WARNING

- When carrying out a counterrotation turn, if the load is not equal on the left and right sides, the machine may carry out a pivot turn, so check the ground conditions and be careful not to hit any obstacles.
- If the steering and directional lever is not operated fully to the forward or reverse position and the lever is operated to turn the machine, the machine may carry out a counterrotation turn, so do not try to turn the machine with the lever partially operated.

If the steering and directional lever is operated partially in the direction of turn with the lever at the N(Neutral) position, the left and right tracks will rotate in opposite directions and the machine will turn smoothly on the spot. If the steering lever is operated fully, the speed of the counterrotation turn will increase.

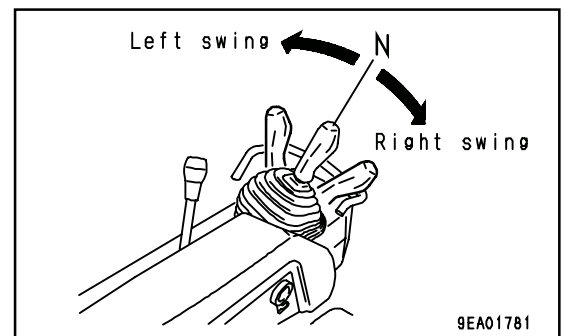

BRAKE PEDAL

WARNING

Do not place your foot on this pedal unnecessarily.

If this pedal(3) is depressed, both brakes are applied simultaneously.

Do not place your foot on this pedal unnecessarily.

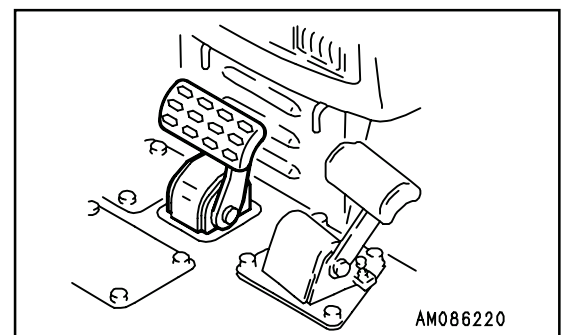

DECELERATION PEDAL

⚠ WARNING

- Do not place your foot on this pedal unnecessarily.
- When passing over the top of a hill or when a load is dumped over a cliff, the load is suddenly reduced, so there is danger that the travel speed will also increase suddenly. To prevent this, depress the decelerator pedal to reduce the travel speed.

This pedal(4) is used to lower the engine speed or stop the engine. Depress this pedal to reduce the speed when shifting between forward and reverse or when stopping the machine.

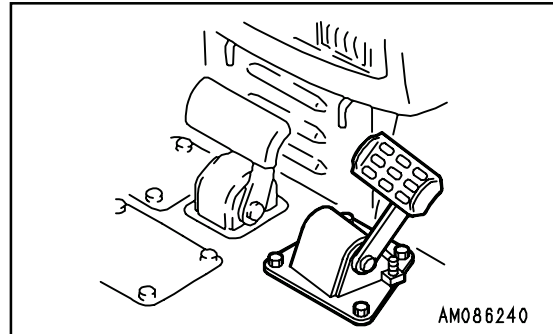

BRAKE LOCK LEVER

⚠ WARNING

- When the machine is parked, always set the brake lock lever to the LOCK position.
- If the brake lock lever is operated, the brake operates even while the machine is traveling. Do not operate the brake lever while the machine is traveling since it stops the machine suddenly, but operate it only in an emergency.

This lever(5) is used to apply the parking brake.

REMARK

- When the steering, directional and gear shift lever is at the FORWARD or REVERSE position, if the brake lock lever is operated to the LOCK position, the steering, directional and gear shift lever will automatically return to the N (neutral) position.
- If the brake lock lever is not at the LOCK position, the limit switch works and the engine does not start.

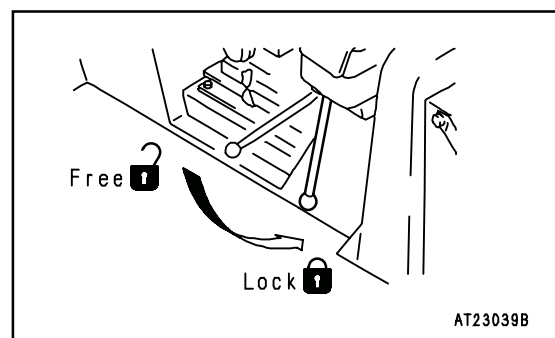

SAFETY LEVER (FOR BLADE CONTROL LEVER)

⚠ WARNING

- When standing up from the operator's seat, always set the safety lever securely to the LOCK position. If the blade control and ripper control levers are not locked and are touched by accident, it may lead to serious injury or damage.
- If the safety lever is not set securely to the LOCK position, the lock may not be applied. Check that it is in the position shown in the diagram.
- When parking the machine or when carrying out maintenance, always lower the blade to the ground, then set the safety lever to the LOCK position.

This safety lever(6) is a device to lock the blade control levers. When it is set to the LOCK position, the TILT, LOWER, RAISE and FLOAT operations are locked.

If the blade control lever is at the FLOAT position and the safety lever is set to the LOCK position, the blade control lever is automatically returned to the HOLD position.

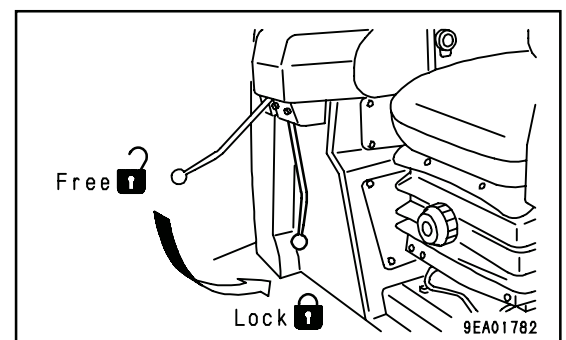

BLADE CONTROL LEVER

POWER ANGLE, POWER TILTDOZER

This lever(7) is used to lift, tilt, or angle the blade.

- Lifting control

- (a)RAISE:
 (b)HOLD: Blade is stopped and held in this position.
 (c)LOWER:
 (d)FLOAT: Blade will move freely according to external force.

REMARK

- When released from FLOAT position, this lever will not return to HOLD position, so it must be moved back by hand.
- Before starting the engine, check that the blade control lever is at the HOLD position.
- In cold weather, it will take time for the lever to be held at the HOLD position, so hold the lever by hand at the HOLD position for at least 1 second.

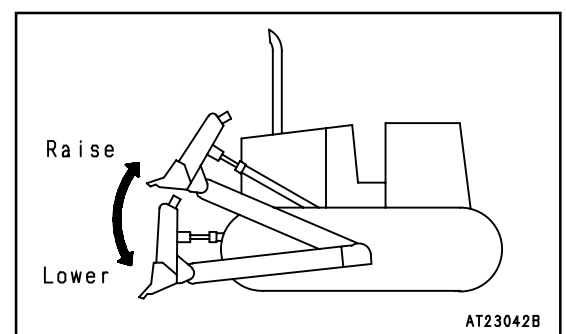
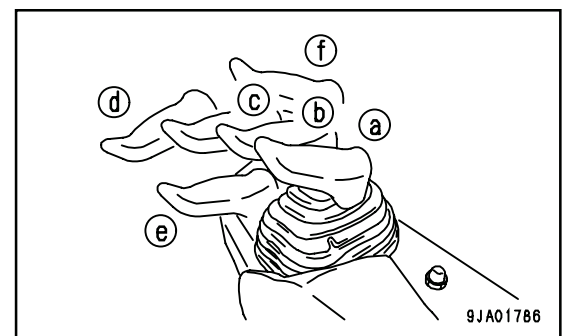

EXPLANATION OF COMPONENTS

OPERATION

● Tilting control

- (e) LEFT TILT
- (f) RIGHT TILT

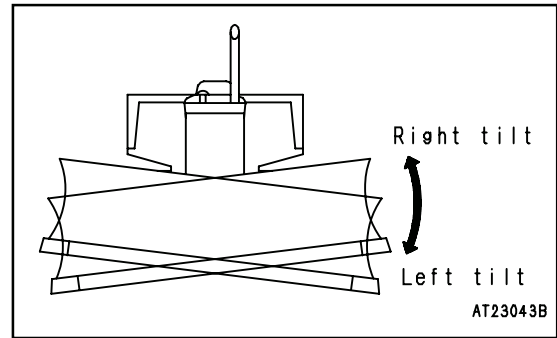

Tilting distance of power angle, power tiltdozer

Condition of blade	Tilting distance		
	STD blade		Wide blade
	D61PX	D61EX	D61EX
Right tilt	600mm (23.6in)	510mm (20.1in)	600mm (23.6in)
Left tilt	600mm (23.6in)	510mm (20.1in)	600mm (23.6in)

● Angling control

- (A) LEFT ANGLE
- (B) HOLD: Blade is stopped and held in this position.
- (C) RIGHT ANGLE

Turn the knob to the right or left to angle the blade.

REMARK

- When performing only angling operation, be sure to set the lever in the neutral (HOLD) position and turn the knob to the right or left.
- If the angling operation is performed while the lever is not in the neutral (HOLD) position (while either or both of lifting and tilting operations are performed), all of those operations can be continued, but the moving speed of the blade is lowered. Select the operations according to the type of the work.
- If the lifting or tilting operation is performed while angling operation is performed, the machine moves similarly to the above.

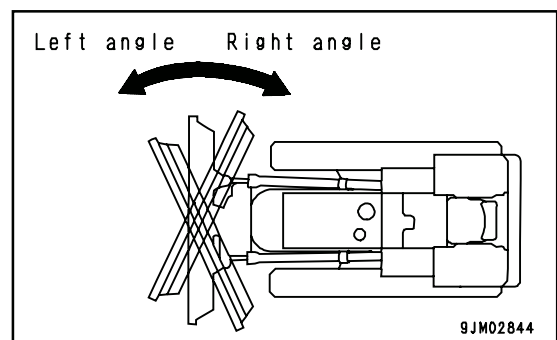
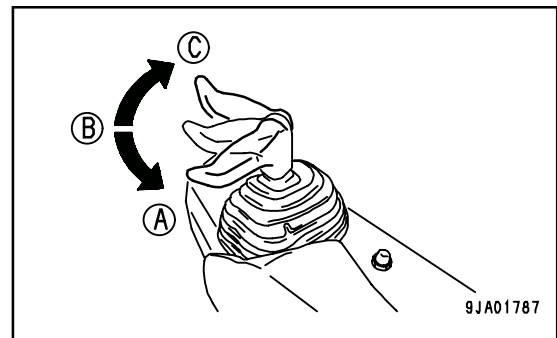

POWER TILTDOZER

This lever(7) is used to lift or tilt the blade.

- Lifting control

- (a)RAISE:
- (b)HOLD: Blade is stopped and held in this position.
- (c)LOWER:
- (d)FLOAT: Blade will move freely according to external force.

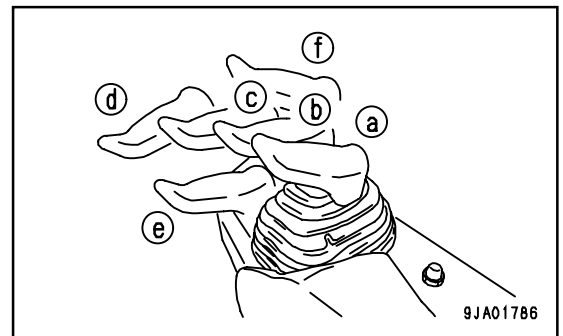

REMARK

- When released from FLOAT position, this lever will not return to HOLD position, so it must be moved back by hand.
- If the engine is stopped when the lever is at the FLOAT position, the control lever will automatically return to the HOLD position.
- Before starting the engine, check that the blade control lever is at the HOLD position.
- In cold weather, it will take time for the lever to be held at the HOLD position, so hold the lever by hand at the HOLD position for at least 1 second.

- Tilting control

- (e)LEFT TILT
- (f)RIGHT TILT

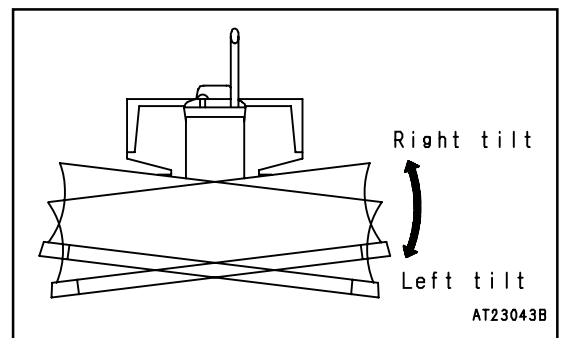
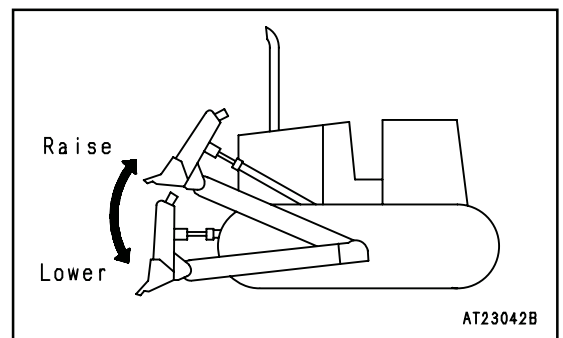

Tilting distance of power tiltdozer (center of blade edge)

Condition of blade	Tilting distance	
	D61PX	D61EX
Right tilt	440mm (15.8in)	500mm (19.7in)
Left tilt	420mm (16.5in)	440mm (17.3in)

FUSE

NOTICE

Before replacing a fuse, be sure to turn off the starting switch.

The fuses protect the electrical equipment and wiring from burning out.

If the fuse becomes corroded, or white powder can be seen, or the fuse is loose in the fuse holder, replace the fuse. Replace a fuse with another of the same capacity.

- Chassis

Fuse boxes(1) and (2) are installed under the battery cover.

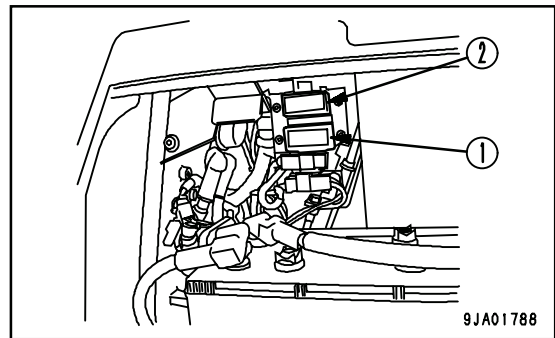

- Cab (machines equipped with cab)

Fuse box(3) is installed at the bottom of the overhead panel.

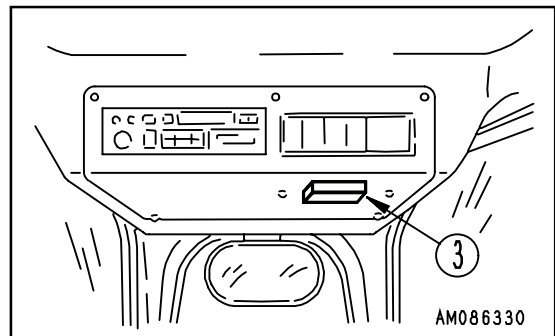

FUSE CAPACITY AND CIRCUIT NAME

Fuse box(1)

No.	Fuse capacity	Name of circuit
(1)	20A	Head lamp, Rear working lamp
(2)	10A	Chassis power source
(3)	10A	(Spare)
(4)	10A	Horn
(5)	10A	Back-up alarm

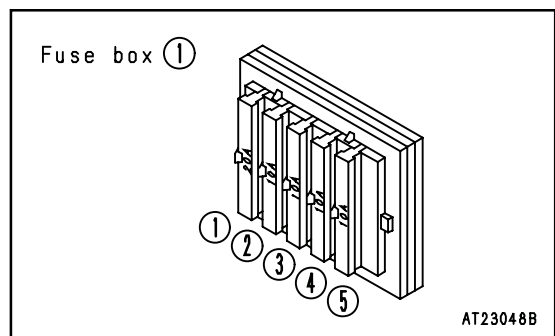

OPERATION

EXPLANATION OF COMPONENTS

Fuse box(2)

No.	Fuse capacity	Name of circuit
(1)	10A	Cab radio, Back-up power source
(2)	10A	(Spare)
(3)	20A	Air conditioner
(4)	20A	Electric power take-out
(5)	30A	Chassis power source

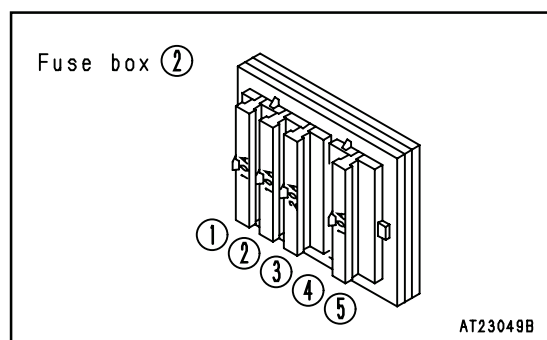

Fuse box(3) (Machine equipped with cab)

No.	Fuse capacity	Name of circuit
(1)	10A	Radio memory
(2)	20A	Radio, lamps, cigarette lighter
(3)	10A	Rear wiper
(4)	10A	Right door wiper
(5)	10A	Front wiper
(6)	10A	Left door wiper

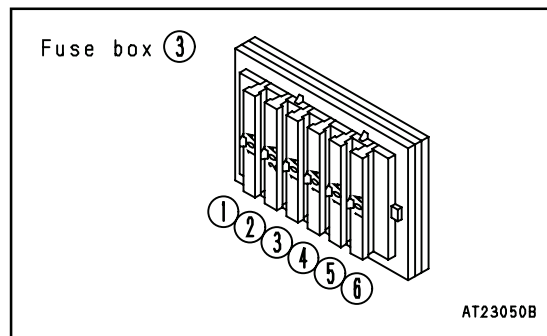

ELECTRIC POWER TAKE-OUT ADAPTER

NOTICE

- Do not use as a power supply for 12V equipment.
This will cause failure of the equipment.
- When using as a power supply pickup, do not install equipment which exceeds 120W (24V x 5A).

(Machine equipped with cab)

It is possible to remove the cigarette lighter and use the socket as a power supply.

Capacity of cigarette lighter: 120W (24V x 5A)

(Machine not equipment with cab)

1. Open battery cover(1) on the left side of the machine.
2. Pull out the electric power take-out connector for the cab.
(A single-pole connector CN25(2) or a single-pole connector CN24(3) for an optional device can be used.)
Connector CN25 and CN26 are secured to the main harness with a band. When using CN25, remove it. After using it, secure it with the band again.
Connector CN24 is secured to the main harness with a tape.

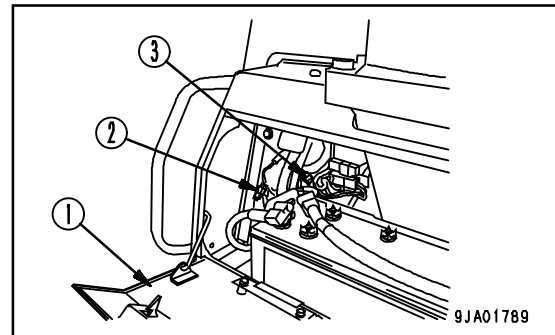

Capacity of each connector:

- CN25(2): 120W(24V x 5A)
- CN24(3): 480W(24V x 20A)

REMARK

- Ground the negative wire to the body work or ROPS. Do not ground it to the rubber mounted engine or valves. This will cause failures.
- If the wire is grounded to a point where there is still paint, the electricity will not flow smoothly, so remove the paint.

DOOR-OPEN LOCK

(Machine equipped with cab)

Use this when you want to keep the door held open.

1. Push the door against the door catch(1). The door will be held by the door catch.

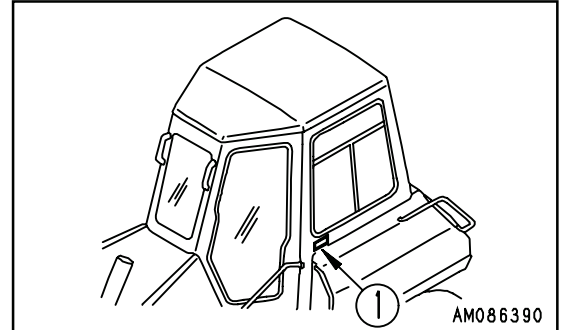

2. To release the door, move lever(2) inside the cab to the front of the cab. This will release the catch.

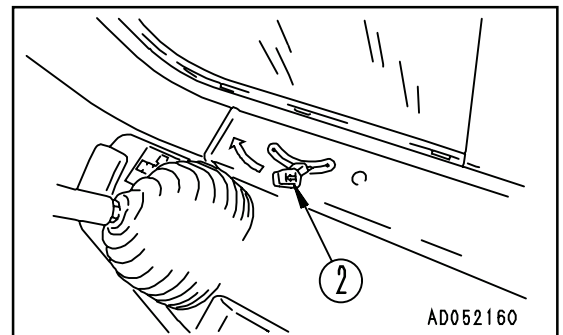

NOTICE

- When keeping the door open, fix it securely to the catch.
- Always close the door when traveling or carrying out operations. Leaving the door open will cause the door to break.
- Keep the door locked open securely. The door may swing closed because of the vibration.

SASH GLASS INTERMEDIATE LOCK

(Machine equipped with cab)

When working with the cab sash glass open, use this lock to prevent the glass from chattering.

- When the lever is at the FREE position, the glass can be opened or closed.
- When the lever is moved to the LOCK (up or down) position, the glass is fixed in position.
- If the glass is not held securely, set the lever in the FREE position and rotate clockwise to strengthen the holding power.
- To reduce the holding power, turn counterclockwise.

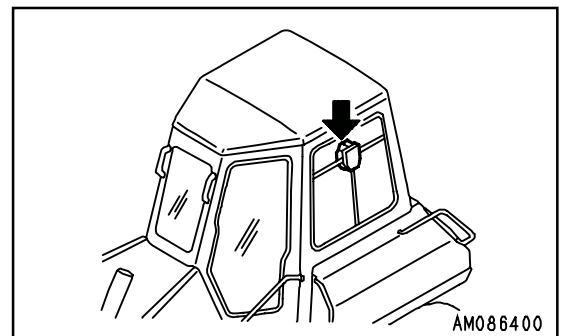

NOTICE

Always close the window when traveling or carrying out operations. Leaving the window open will cause the window to break.

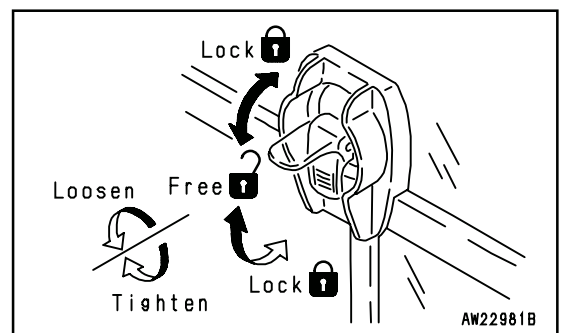

CAP, COVER WITH LOCK

The fuel tank cap, hydraulic tank cap, cab door opener, front top cover of the machine, battery check cover, both engine side covers, drain valve of the fuel tank, and inspection cover are equipped with locks.

Use the starting switch to open those caps and covers.

Insert the key as far as it will go to the shoulder. If the key is turned before it is inserted all the way, it may break.

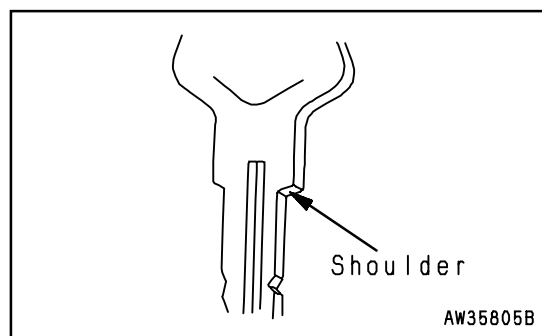

METHOD OF OPENING AND CLOSING CAP WITH LOCK

TO OPEN THE CAP

1. Insert the key into the key slot.
2. Turn the key clockwise, align the key slot with the match mark on the cap, then open the cap.

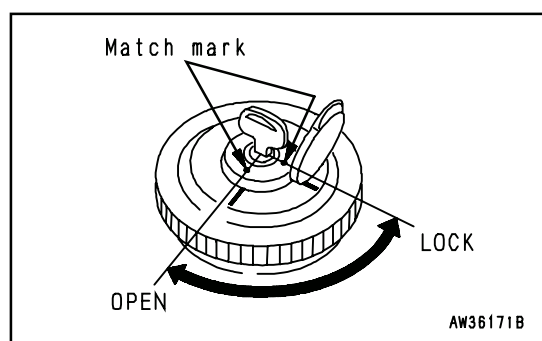

TO LOCK THE CAP

1. Turn the cap into place and insert the key into the key slot.
2. Turn the key counterclockwise and take the key out.

METHOD OF OPENING AND CLOSING COVER WITH LOCK

TO OPEN THE COVER(LOCKED COVER)

1. Insert the key into the key slot.
2. Turn the key counterclockwise and open the cover by pulling the cover grip.

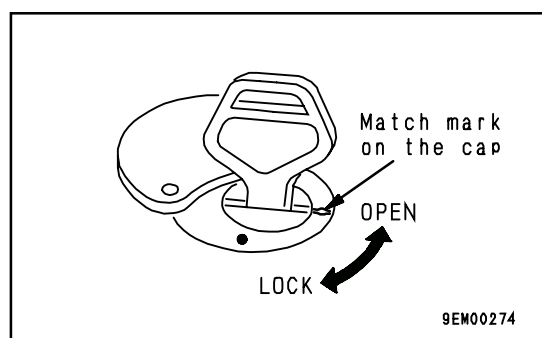

TO LOCK THE COVER

1. Close the cover and insert the key into the key slot.
2. Turn the key clockwise and take the key out.

HOT AND COOL BOX

(Machine equipped with cab)

This is at the top of the front panel. It can be used to warm or cool three canned drinks.

This is interconnected with the air conditioner: During heating, it warms up the drinks; during cooling, it cools to the drinks.

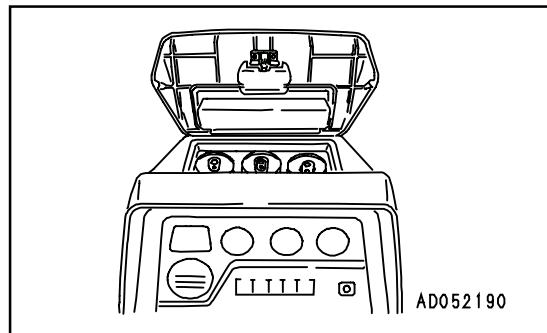

OPERATION MANUAL STORAGE

(Machine equipped with cab)

These are on the inside of the left and right doors, and can be used for keeping things or Operation & Maintenance manual.

However, do not put tools or other heavy objects in the pocket. If the pocket becomes dirty, turn three clips(1), remove the pocket and wash it.

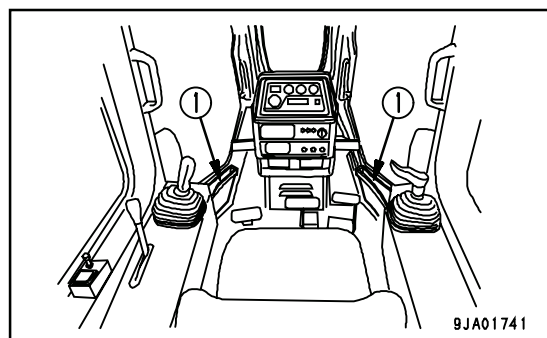

(Machine not equipment with cab)

There is a pocket on the back of the operator's seat.

Keep the operation manual in this pocket so that the operator can read it whenever necessary.

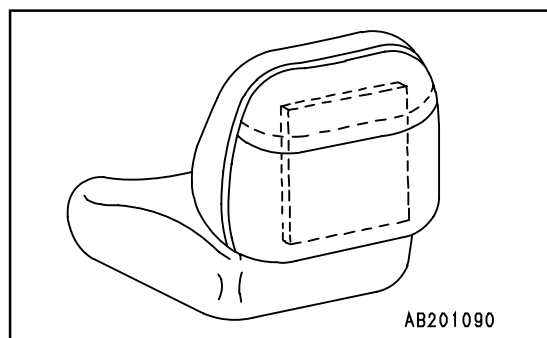

ASHTRAY

(Machine equipped with cab)

This is on the left side of the operator's seat.

Always make sure that you extinguish the cigarette before closing the lid.

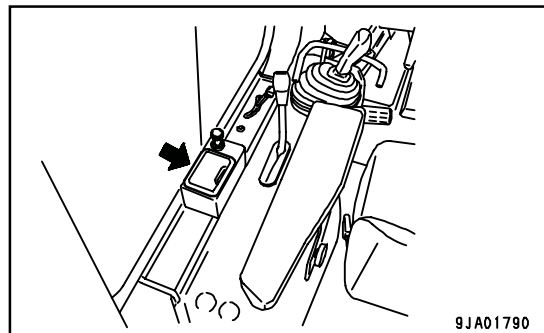

TOOL BOX

The tool box is inside the battery check cover at the rear left. Keep the tools in this box.

The grease pump can be put in this box without removing the nozzle.

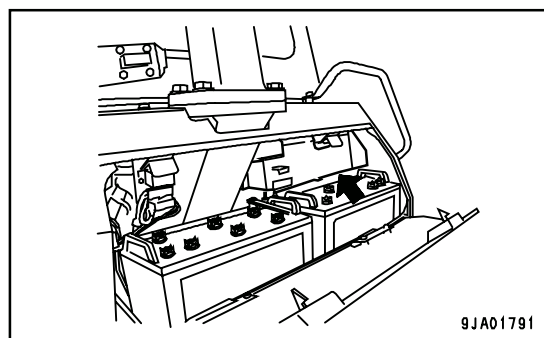

AIR CONDITIONER

(Machine equipped with cab, air conditioner)

EXPLANATION OF PARTS

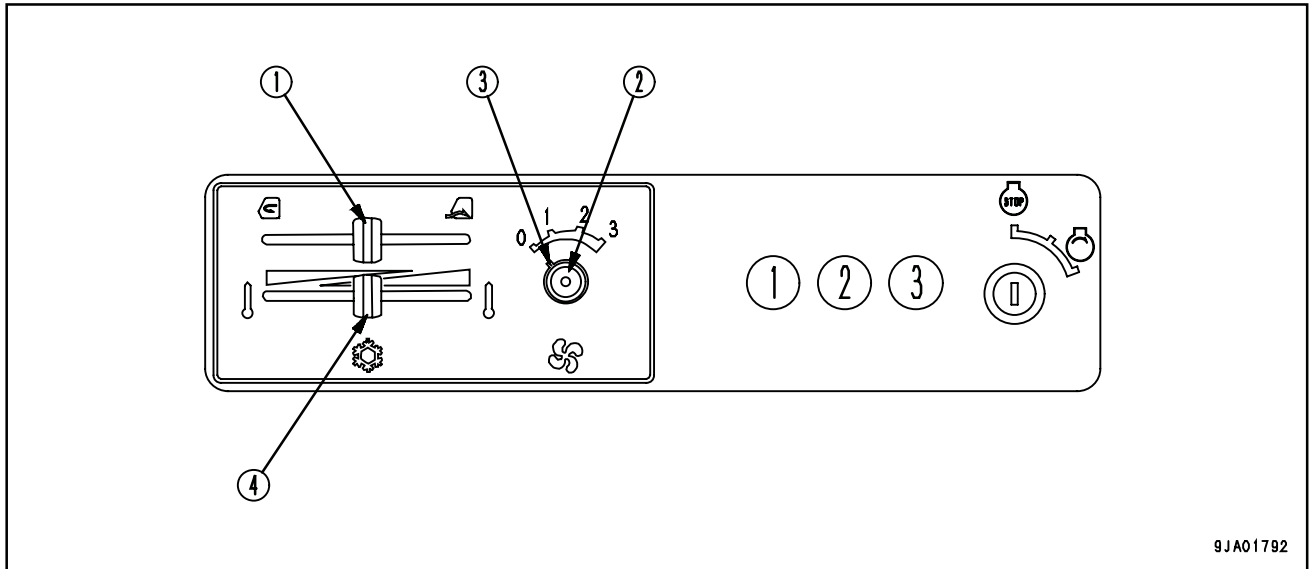

9JA01792

- | | |
|---------------------------------|-------------------------------|
| (1) Fresh/recirc selector lever | (3) Blower switch |
| (2) Air condition switch | (4) Temperature control lever |

FRESH/RECIRC SELECTOR LEVER

This lever(1) changes the air intake port used when cooling or heating.

- **RECIRC:** If lever(1) is shifted to the left, the air conditioner sucks inside air. Set the lever to this position to cool or heat strongly. Ventilation or pressurizing function is not applied at this position.
- **FRESH:** If lever(1) is shifted to the right, the air conditioner sucks outside air. Set the lever to this position for normal cooling or heating. In this position, the cab is ventilated. It is also pressurized to prevent entry of dust.

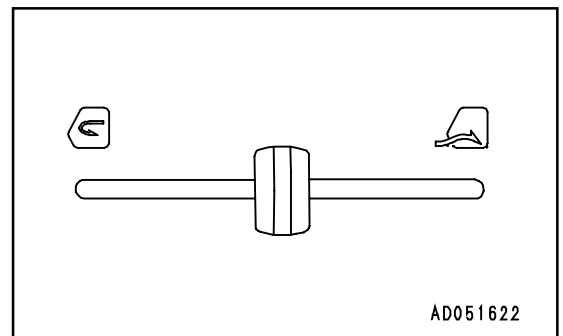

AD051622

AIR CONDITION SWITCH

When the switch(2) is pressed and the blue lamp lights up, the cooling function is actuated. Use this switch for cooling or dehumidifying.

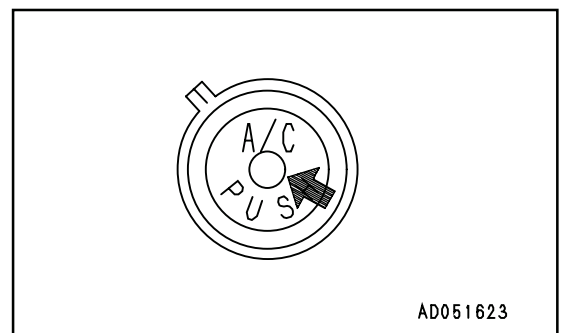

AD051623

BLOWER SWITCH

This switch(3) acts as the wind flow control switch and main switch when cooling or heating.

- The air flow can be set to three stages:
1(LOW) → 2(MEDIUM) → 3(HIGH).
- If the switch is set to 0, the power is switched off and the air conditioner stops.

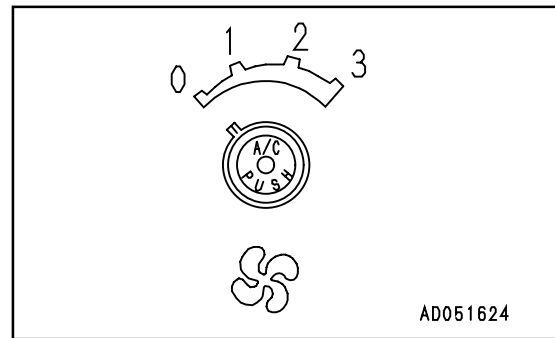

TEMPERATURE CONTROL LEVER

This lever(4) is used to control the temperature for cooling or heating.

- When the temperature control lever is moved to the right, the temperature of the air coming from the vents becomes lower. (The water valve is closed and the heating function is stopped.)
- When the temperature control lever is moved to the left, the temperature of the air coming from the vents becomes higher. (The water valve is opened and the heating function is started.)

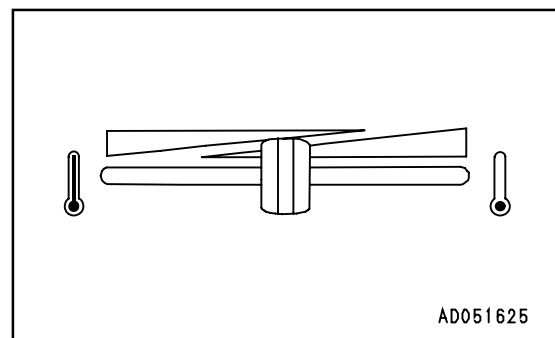

COOLING OPERATION

When the cooling operation is carried out, the inside of the cab is cooled, and at the same time the drinks inside the hot and cool box can be cooled.

COOLING (RECIRC)

When the control switch and lever are operated as shown in the diagram, a cool breeze is sent out. Use this position when strong cooling is needed.

- Press switch(2).
- Place levers(1) and(4) in the position shown in the diagram.
- Set switch(3) to the desired position.

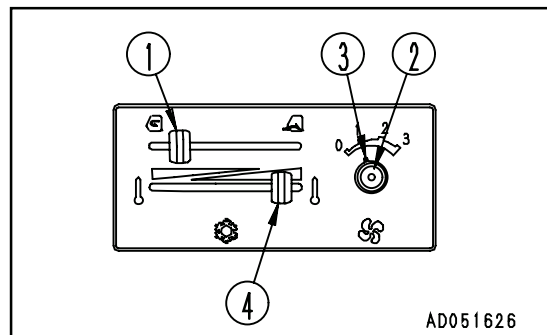

COOLING (FRESH)

If the air inside the cab is no longer fresh, set FRESH/RECIRC selector lever 1 to FRESH to bring in fresh air. Keep the other switches at the same positions as for cooling (RECIRC). In this position, the inside of the cab is pressurized to prevent the entry of dust.

REMARK

- If the cooling effect is reduced, set FRESH/RECIRC selector lever(1) to RECIRC again. This increases the cooling effect.
- New Freon R134a is used as the refrigerant.
- Tighten the air conditioner gas piping screws to the following torque.

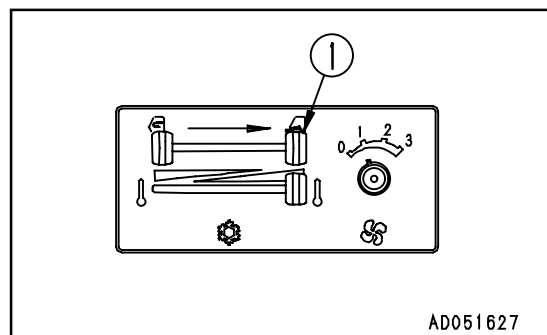

HEATING OPERATION

When the heating operation is carried out, the inside of the cab is heated, and at the same time the drinks inside the hot and cool box can be heated.

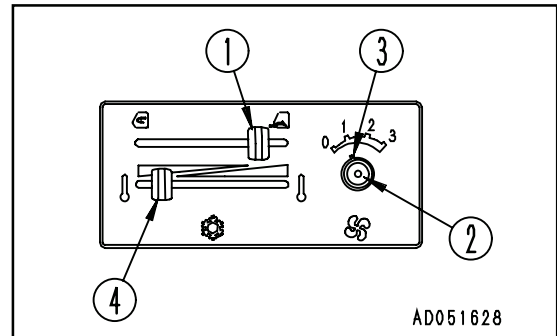

HEATING (RECIRC)

When the control switch and lever are operated as shown in the diagram, warm air is sent out. Use this position when strong cooling is needed.

- Place levers(1) and (4) in the position shown in the diagram.
- Set switch(3) to the desired position.

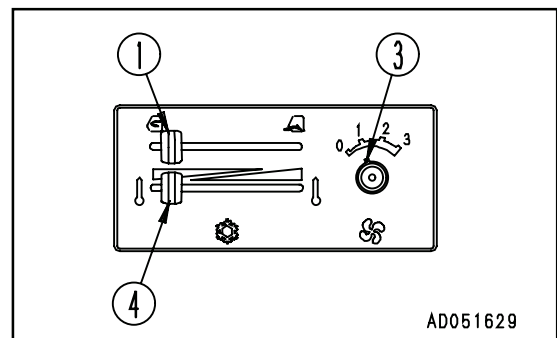

HEATING (FRESH)

If the air inside the cab is no longer fresh, set FRESH/RECIRC selector lever(1) to FRESH to bring in fresh air. Keep the other switches at the same positions as for cooling (RECIRC). In this position, the inside of the cab is pressurized to prevent the entry of dust.

REMARK

If the cab is not heated up sufficiently, turn FRESH/RECIRC selector lever(1) back to RECIRC. This increases the heating effect.

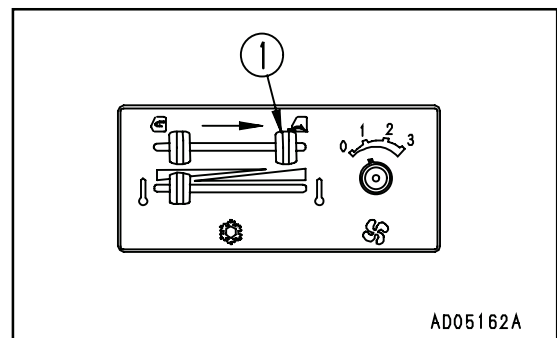

DEHUMIDIFYING AND HEATING

Push switch(2). When temperature control lever(4) is placed at the central position, dry warm air blows out.

Keep the other switches at the same positions as for heating (FRESH).

REMARK

If this is used in spring and fall on rainy days when the air inside the cab is damp, there is no problem of the windows misting up, and the cab be warmed up to a comfortable temperature.

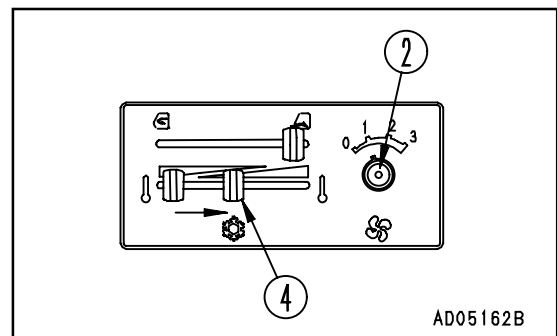

PREVENTION METHOD OF ENTRY OF DUST

Entry of dust into the cab can be prevented by starting the blower fan for the air conditioner to raise the pressure in the cab a little higher than outside.

When working in a dusty job site or when preventing dust from entering the cab, use this function.

- Close the windows and doors.
- Set lever(1) to the FRESH position.
- Press swith(2).
- Set switch(3) to the desired position.
- Set lever(4) to the desired position.

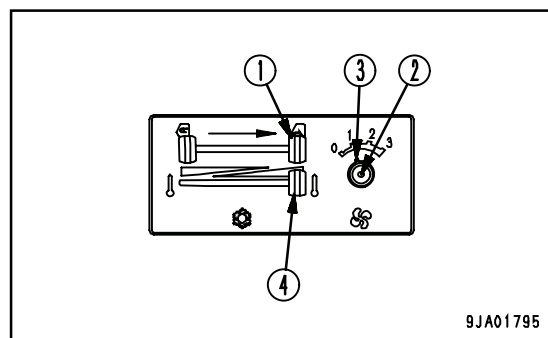

PRECAUTION WHEN USING AIR CONDITIONER

CARRY OUT VENTILATION FROM TIME TO TIME WHEN USING THE COOLER.

- If you smoke when the cooler is on, the smoke may start to hurt your eyes, so turn the lever to FRESH to remove the smoke while continuing the cooling.
- When the air conditioner is used for long periods, carry out ventilation once every hour.

BE CAREFUL NOT TO MAKE THE TEMPERATURE IN THE CAB TOO LOW.

- When the cooler is on, set the temperature so that it feels slightly cool when entering the cab (5 to 6°C lower than the outside temperature). This temperature difference is considered to be the most suitable for your health, so always be careful to adjust the temperature properly.

DIRECTION OF VENTS WHEN COOLING

- If the vents (left and right) in the middle of the dashboard are turned so that cold air plays directly on the cab door glass, moisture may condense on the outside of the cab door glass and reduce the visibility. (This occurs particularly in high temperatures.)
If this happens, turn the vent fully to the rear and raise the air conditioner temperature setting slightly.

INSPECTION DURING OFF-SEASON

Even during the off-season, run the compressor at low speed for several minutes once a week to prevent the loss of the oil film at the lubricated parts of the compressor. (Run the engine at low speed and set the temperature control lever at the central position.)

REMARK

When the ambient temperature is low, if the compressor is suddenly run at high speed, it may cause failure of the compressor. Note that the system is set so that the compressor will not run when the cooler switch is turned on if the ambient temperature is less than 2 to 6.5°C.

PROCEDURE FOR REPLACING RECEIVER

Replace the receiver once every two years.

After replacing the receiver, add compressor oil. Turn the receiver at an angle and measure the oil remaining inside the receiver, then add the same amount of oil (Denso Oil 6) to fill the receiver.

REMARK

- Depending on the condition of use, the replacement interval may be shorter.
- If the receiver is used when the desiccant has exceeded the water absorption limit, the refrigerant circuit may become clogged and cause failure of the compressor.

PRECAUTIONS WHEN REPLACING RECEIVER

- If the receiver is left for more than 15 minutes with the blind cover removed, the moisture in the air will be absorbed, and this will reduce the life of the desiccant. If you remove the blind cover, connect the piping quickly, evacuate the system and fill with refrigerant.
- When removing the refrigerant from the refrigerant circuit, release it gradually from the low pressure side to prevent oil from flowing out.

CLEANING AIR FILTER

If the air filter for the FRESH or RECIRC air intake becomes clogged, the cooling or heating capacity will drop. In places where there is a lot of dust, clean the air with compressed air once a week. For details of the cleaning method, see "CLEAN AIR CONDITIONER AIR FILTER (FRESH/RECIRC FILTER) (PAGE 4-47)".